

Company: Joyoung International Trading Co., Limited
Atten: Smiling
Mobile/WhatsApp: +86 18050035902
E-mail: info@htechplc.com
Website: <https://www.joyoungintl.com/>

Machinery Health™ Sensor

PR 9268/xxx-xxx, Absolute Vibration Transducers



Copyright

© 2022 by Emerson. All rights reserved.

No part of this publication may be reproduced, transmitted, transcribed, stored in a retrieval system, or translated into any language in any form by any means without the written permission of Emerson.

Disclaimer

This manual is provided for informational purposes. EMERSON MAKES NO WARRANTY OF ANY KIND WITH REGARD TO THIS MATERIAL, INCLUDING, BUT NOT LIMITED TO, THE IMPLIED WARRANTIES OF MERCHANTABILITY AND FITNESS FOR A PARTICULAR PURPOSE. Emerson shall not be liable for errors, omissions, or inconsistencies that may be contained herein or for incidental or consequential damages in connection with the furnishing, performance, or use of this material. Information in this document is subject to change without notice and does not represent a commitment on the part of Emerson. The information in this manual is not all-inclusive and cannot cover all unique situations.

Patents

The product(s) described in this manual are covered under existing and pending patents.

 Vermerk zur Installation der Messketten in explosionsgefährdeter Umgebung.
Soll die Messkette in explosionsgefährdeter Umgebung installiert werden, so ist auf die Einhaltung der in der Gebrauchsanweisung enthaltenen Installationshinweise zu achten. Sollten dabei sprachliche Schwierigkeiten auftreten, wenden Sie sich bitte an die Herstellerfirma, sie wird Ihnen eine Übersetzung der relevanten Artikel in der Landessprache des Verwendungslandes zukommen lassen.

 Nota fuq l-installazzjoni tal-ktajjen tal-kejl f'ambjent esploziv
Jekk il-katina tal-kejl suppost li tigi installata f'ambjent esploziv, hu importanti li ssegwi l-istruzzjonijiet pertinenti tal-manwal. Jekk issib xi diffikultà bil-lingwa, jekk joghgbok ikkuntattja lill-manifattur biex tikseb traduzzjoni tal-paragrafi rilevanti fil-lingwa mehtiega.

 Anmärkning beträffande installation av mätkedjorna i explosionsfarlig miljö.
Ska mätkedjan installeras i explosionsfarlig miljö, måste de anvisningar följas som ges i instruktionsboken beträffande installationen. Skulle därvid språkproblem uppstå, ber vi dig kontakta det tillverkande företaget som då kommer att sända dig en översättning av de relevanta artiklarna på användningslandets språk.

 Opomba za namestitve merilne verige v eksplozivno ogroženem okolju
Èe se merilna veriga namešèa v eksplozivno ogroženem okolju, je potrebno upoštevati namestitvena opozorila, ki so v Navodilih za uporabo. Èe se pri tem pojavijo jezikovne težave, se posvetujte z izdelovalcem; poslali vam bodo prevod ustreznih èlankov v jeziku države, kjer se naprava uporablja.

 Záznam k inštalácii meracích reťazcov vo výbušnom prostredí
Ak má byť merací reťazec inštalovaný vo výbušnom prostredí, treba dbať na dodržiavanie pokynov k inštalácii, uvedených v návode na použitie. V prípade, že by sa pritom vyskytli jazykové problémy, obráťte sa prosím na výrobcu, ktorý Vám zašle preklad relevantných èlánkov v jazyku Vašej krajiny.

 Nota referente à instalação de cadeias de agrimensur em ambientes potencialmente explosivos
Caso a cadeia de agrimensur deva ser instalada em um ambiente potencialmente explosivo, é imprescindível observar e cumprir as indicações de instalação das instruções de serviço. Caso tenha dificuldades idiomáticas, queira entrar em contato com a firma produtora, esta poderá enviar-lhe uma tradução dos capítulos mais importantes no idioma do país onde o produto deverá ser empregado.

 Wskazówka dotycząca instalacji łańcuchów mierniczych w otoczeniach zagrożonych eksplozją.
Jeżeli łańcuch mierniczy ma być zainstalowany w otoczeniu zagrożonym eksplozją, należy uwzględnić wskazówki dotyczące instalacji, które są zawarte w instrukcji obsługi. Jeżeli w trakcie lektury wystąpią jakiegokolwiek problemy związane ze zrozumieniem tekstu, prosimy zwrócić się do producenta, który chętnie wykona tłumaczenie wybranych części dokumentacji na język danego kraju.



Opmerking m.b.t. installatie van elektrische meet circuits in explosiegevaarlijke omgeving

Dient de installatie van elektrische meet circuits in een explosiegevaarlijke omgeving te geschieden, moet men toezien dat de in de gebruikshandleiding opgenomen installatieinstructies worden nageleefd. Bij taalkundige problemen gelieve contact op te nemen met de fabrikant, deze zal u vervolgens een vertaling in de taal van het gebruiksland doen toekomen.



Pastaba dėl matavimo grandinės įrengimo sprogimo atžvilgiu pavojingoje aplinkoje

Jei matavimo grandinė turi būti įrengta sprogimo atžvilgiu pavojingoje aplinkoje, privaloma laikytis vartotojo instrukcijoje pateiktų įrengimo nurodymų. Jei kiltų sunkumų dėl kalbos, prašome kreiptis į gamintojo įmonę, kuri pateiks Jums reikiamo skyriaus vertimą į vartotojo valstybės kalbą.



Nota sull'installazione delle catene per misurazione in ambienti a rischio di esplosioni

Nel caso in cui si debbano installare le catene per misurazione in ambienti a rischio di esplosioni, è necessario attenersi alle avvertenze per l'installazione contenute nelle istruzioni d'uso. Per difficoltà di carattere linguistico, rivolgetevi alla ditta produttrice. Quest'ultima Vi farà pervenire una traduzione degli articoli rilevanti nella lingua del paese d'impiego.



Megjegyzés a mérőláncok robbanásveszélyes környezetben történő szereléséhez.

Ha a mérőláncot robbanásveszélyes környezetben kell felszerelni, akkor ügyeljen a Használati útmutatóban közölt szerelési utasítások betartására. Amennyiben nyelvi nehézségek merülnek fel, szíveskedjen a gyártó céghez fordulni, amely elküldni Önnek a felhasználó ország nyelvére lefordított, erre vonatkozó cikket.



Remarque concernant l'installation des chaînes de mesure dans un environnement présentant un risque d'explosion

Si la chaîne de mesure doit être installée dans un environnement présentant un risque d'explosion, il est impératif de veiller à respecter les consignes d'installation contenues dans les instructions de service. S'il devait ce faisant surgir des problèmes linguistiques, veuillez vous adresser à la société fabricante: elle vous fera parvenir une traduction des articles significatifs dans la langue du pays de mise en oeuvre.



Huomautus mittausketjun asentamisesta räjähdysalttiissa ympäristössä

Jos mittausketju tulee asentaa räjähdysalttiissa ympäristössä, on käyttöohjeessa annettuja asennusohjeita noudatettava. Jos käyttöohjeessa käytetty kieli aiheuttaa ongelmia, kääntykää valmistajayrityksen puoleen. Se toimittaa käyttöönnne tarvittavat artikkelit käyttömaan viralliselle kielelle käännettynä.



Juhend mõõdukettide ülespanemiseks plahvatusohtlikus piirkonnas.

Kui panna üles mõõdukettid plahvatusohtlikkus piirkonnas, nii tuleb jälgida kasutusjuhendis sisalduvad instalationimärkmeid. Juhul kui tekkivad raskused keelega, siis pöörduge palun tootja poole. Tootja saadab emakeelse tõlge vastavalt artiklile ning maale.



Notas sobre la instalación de cadenas de medición en un entorno potencialmente explosivo.

Si ha de instalar la cadena de medición en un entorno potencialmente explosivo, deberá respetar las indicaciones sobre la instalación, contenidas en el manual de uso. Si surgieran dificultades lingüísticas, póngase en contacto con la empresa fabricante, que le facilitará una traducción del artículo en la lengua del país donde se emplee.



Note on the installation of the measuring chains in an explosive environment

If the measuring chain is supposed to be installed in an explosive environment, it is important to follow the pertinent installation instructions in the manual. Should you encounter difficulties with the language, please contact the manufacturer to obtain a translation of the relevant paragraphs into the language required.



Σημείωση για την εγκατάσταση αλυσίδων μέτρησης σε περιβάλλον, στο οποίο υπάρχει κίνδυνος έκρηξης
Εάν η αλυσίδα μέτρησης πρόκειται να εγκατασταθεί σε περιβάλλον, στο οποίο υπάρχει κίνδυνος έκρηξης, πρέπει να τηρηθούν οπωσδήποτε οι οδηγίες εγκατάστασης που περιλαμβάνονται στις οδηγίες Χρήσης. Εάν υπάρχουν γλωσσικές δυσκολίες καταούησης, παρακαλούμε να απευθυνθείτε στην κατασκευάστρια εταιρεία, η οποία θα φρουτίσει για την αποστολή μιας μετάφρασης τωv σχετικωv άρθρωv στη γλωσσα της Χωρας Χρήσης.



Info vedrørende installation af målekæderne i eksplosionstruede omgivelser

Hvis målekæden skal installeres i eksplosionstruede omgivelser, skal installationsanvisningerne i brugsanvisningen følges. Hvis der i denne forbindelse opstår sproglige problemer, bedes De henvende Dem til produktionsfirmaet, som så vil sørge for, at De modtager en oversættelse af den relevante artikel på Deres sprog.



Poznámka k instalaci měřicích řetězců v prostředí s nebezpečím výbuchu.

Když má být měřicí řetězec (sestavující z čidla a konvertoru) instalován v prostředí s nebezpečím výbuchu, tak je třeba respektovat instalační pokyny, které jsou součástí návodu k upotřebení. Kdyby při tom došlo k jazykovým potížím, tak prosíme kontaktujte výrobní firmu, která Vám relevantní článek zašle v jazyku krajiny použití.



Piezīme par mērišanas ķēžu instalēšanu sprādziena bīstamās zonās.

Ja mērišanas ķēde jāuzstāda sprādzienbīstamā zonā, ir jāievēro lietošanas instrukcijā dotie instalēšanas norādījumi. Ja rodas kādas valodas grūtības, lūdzu griezieties pie izgatavotāja firmas, kas Jums nosūtīs nozīmīgāko nodaļu tulkojumus lietotāja valsts valodā.

Emerson
epro GmbH
Jöbkesweg 3
48599 Gronau
Germany
T +49 2562 709 0
F +49 2562 709 401
www.Emerson.com

Contents

Chapter 1	General.....	7
	1.1 Using this manual.....	7
	1.2 Symbols.....	7
	1.3 Liability and guarantee.....	8
	1.4 Incoming goods inspection.....	8
	1.5 Technical support.....	9
	1.6 Storage and transport.....	9
	1.7 Disposal of the device.....	9
	1.8 China RoHS Compliance.....	10
	1.9 Installation awareness.....	10
Chapter 2	Safety instructions.....	11
	2.1 Using the device.....	11
	2.2 Owner's responsibility.....	11
	2.3 Radio interference.....	11
	2.4 ESD safety.....	12
Chapter 3	Application and design.....	13
	3.1 Application.....	13
	3.2 Design.....	13
Chapter 4	Installation and commissioning.....	17
	4.1 Hints for installation and connection.....	17
	4.2 CSA - Conditions of acceptability.....	24
	4.3 Installation requirements depending on mounting angle.....	25
	4.3.1 PR 9268/20x-x00 and PR 9268/60x-000 – without sinking current.....	26
	4.3.2 PR 9268/20x-x00 and PR 9268/60x-000 – with sinking current.....	26
	4.3.3 PR 9268/30x-x00 and PR 9268/70x-000 – without lifting/sinking current.....	27
	4.3.4 PR 9268/30x-x00 and PR 9268/70x-000 – with lifting current.....	28
	4.3.5 PR 9268/30x-x00 and PR 9268/70x-000 – with sinking current.....	29
Chapter 5	Maintenance, fault finding, and repair.....	31
	5.1 Maintenance.....	31
	5.2 Hints for fault finding.....	31
	5.2.1 Transducer resistance measurement.....	31
	5.2.2 Insulation resistance measurement.....	31
	5.2.3 Signal generation check.....	32
	5.3 Repair.....	32
Chapter 6	Technical data.....	33
	6.1 Measuring principle.....	33
	6.2 Operating ranges.....	34

6.3	Electrical data.....	37
6.4	Environmental conditions and dimensions.....	38
Chapter 7	Hazardous location installation.....	45
7.1	Installation requirements.....	45
7.2	Operation requirements.....	46
7.3	Technical data, explosion protection.....	46
7.4	Drawings.....	48
7.5	Revision history.....	50
Chapter 8	Certificates.....	51
Index	55

1 General

1.1 Using this manual

This manual contains information concerning the use of the device.

Read the operating manual completely prior to starting installation and operating the device. Comply with all safety instructions.

This operating manual applies for the following absolute vibration transducers:

- PR 9268/01x-x00
- PR 9268/20x-x00
- PR 9268/30x-x00
- PR 9268/60x-000
- PR 9268/70x-000

The CSA approval is valid for all absolute vibration transducers listed in [Table 1-1](#) with a serial number higher than the stated serial number. See type plate of the transducer for serial number.

Table 1-1: Serial number limit for CSA approval

Absolute vibration transducer	Serial number
PR 9268/01x-x00	>2000
PR 9268/20x-x00	>10000
PR 9268/30x-x00	
PR 9268/60x-000	>4000
PR 9268/70x-000	

Include the operating manual when transferring the device to third parties.

Note

When requesting technical support, indicate type and serial number from the type plate.

[Table 1-2](#) shows a list of documents that are referred to in this operating manual.

Table 1-2: Referenced documents

MHM-97877	Operating Manual A6500-xR System Rack
MHM-97416	Operating Manual A6120 Bearing Vibration Monitor

1.2 Symbols

Note

This symbol marks passages that contain important information.

⚠ CAUTION

This symbol marks operations that can lead to malfunctions or faulty measurements, but will not damage the device.

⚠ DANGER

A danger indicates actions that can lead to property damage or personal injury.



According to IEC 61010, this symbol means that the documentation of the device must completely be read and understood before installing and commissioning of the device. Observe all safety related instructions in this document.

1.3 Liability and guarantee

Emerson is not liable for damages that occur due to improper use. Proper use also includes the knowledge of, and compliance with, this document.

Customer changes to the device that have not been expressly approved by Emerson will result in the loss of guarantee.

Due to continuous research and further development, Emerson reserves the right to change technical specifications without notice.

1.4 Incoming goods inspection

Check the content of the shipment to ensure that it is complete; visibly inspect the goods to determine if the device has been damaged during transport. The following parts are included in the scope of delivery and must be contained in the shipment.

- PR 9268/01x-x00, PR 9268/20x-x00, PR 9268/30x-x00, PR 9268/60x-000, or PR 9268/70x-000 Absolute Vibration Transducer
- Harting socket including female contact strip, housing, and cover (only transducers with Harting plug)
- Plastic bag with screws M6x20, washers, and cable gland M20 (only PR 9268/60x-000 and PR 9268/70x-000)
- Mounting bolt M10x1 to M6 (only PR 9268/01x-x00)
- Documentation CD with Installation guide

If the contents are incomplete, or if you observe any defects, file a complaint with the carrier immediately. Inform the responsible Emerson sales organization so your device can be replaced. In this case, attach a tag with customer name and the observed defect.

1.5 Technical support

You may need to ship this product for return, replacement, or repair to an Emerson Product Service Center. Before shipping this product, contact Emerson Product Support to obtain a Return Materials Authorization (RMA) number and receive additional instructions.

Product Support

Emerson provides a variety of ways to reach your Product Support team to get the answers you need when you need them:

Phone	Toll free 800.833.8314 (U.S. and Canada) +1.512.832.3774 (Latin America) +63.2702.1111 (Asia Pacific, Europe, and Middle East)
Email	Guardian.GSC@Emerson.com
Web	http://www.emerson.com/en-us/contact-us

To search for documentation, visit <http://www.emerson.com>.

To view toll free numbers for specific countries, visit <http://www.emersonprocess.com/technicalsupport>.

Note

If the equipment has been exposed to a hazardous substance, a Material Safety Data Sheet (MSDS) must be included with the returned materials. An MSDS is required by law to be available to people exposed to specific hazardous substances.

1.6 Storage and transport

Store and transport the device only in its original packaging. Technical data specifies the environmental conditions for storage and support.

Related information

[Technical data](#)

1.7 Disposal of the device

Provided that no repurchase or disposal agreement exists, recycle the following components at appropriate facilities:

- Recyclable metal
- Plastic elements

Sort the remaining components for disposal, based on their condition. National laws or provisions on waste disposal and protection of the environment apply.

Note

Environmental hazards! Electrical waste and electronic components are subject to treatment as special waste and may only be disposed by approved specialized companies.

1.8 China RoHS Compliance

Our products manufactured later than June 30, 2016 and those which are sold in the People's Republic of China are marked with one of the following two logos to indicate the Environmental Friendly Use Period in which it can be used safely under normal operating conditions.

Products without below mentioned marking are either manufactured before June 30 or are non-electrical equipment products (EEP).



Circling arrow symbol with "e": The product contains no hazardous substances over the Maximum Concentration Value and it has an indefinite Environmental Friendly Use Period.



Circling arrow symbol with a number: This product contains certain hazardous substances over the Maximum Concentration Value and it can be used safely under normal operating conditions for the number of years indicated in the symbol. The names and contents of hazardous substances can be found in the folder "China RoHS Compliance Certificates" on the documentation CD or DVD enclosed with the product.

1.9 Installation awareness

Note

When planning a measurement, observe the following items:

- Consider environmental conditions which might have an influence on the measurement such as temperature, humidity, substances aggressive to the sensor, and pollution.
 - Always use a stiff and vibration-free sensor holder.
 - Define a suitable measuring range, not larger than necessary, in consultation with the operator of the plant.
 - Define the trip limit in consultation with the operator of the plant.
 - Take measurement deviations into account when defining the trip limit.
 - Use a sensor that meets the requirements of the defined measuring range.
 - Ensure an EMC-compatible installation including the use of proper cables.
 - Ensure proper function of the measurement before activating the measurement for regular operation.
-

2 Safety instructions

To ensure safe operation, carefully observe all instructions in this manual.

The correct and safe use of this device requires that operating and service personnel both understand and comply with general safety guidelines and observe the special safety comments listed in this manual. Where necessary, safety-sensitive points on the device are marked.

⚠ DANGER

Because the device is electrical equipment, commissioning and service must be performed only by trained and authorized personnel. Maintenance must be carried out only by trained, specialized, and experienced personnel.

2.1 Using the device

Install and use the device as specified in this manual.

If the device is used in a manner not specified by the manufacturer, the protection provided by the device may be impaired.

2.2 Owner's responsibility

If there is a reason to suspect that hazard-free operation, and thus, adequate machine protection is no longer possible, take the device out of operation and safeguard it from unintentional operation. This is the case:

- if the device shows visible damage.
- if the device no longer works.
- after any kind of overload that has exceeded the permissible limits (such as those detailed in chapter "Technical data," section "Environmental conditions").

Related information

[Technical data](#)

2.3 Radio interference

The device is carefully shielded and tested to be technically immune to radio interference and complies with current standards. However, if you operate this device together with other peripheral devices that are not properly shielded against radio interference, disturbances and radio interferences may occur.

2.4 ESD safety

⚠ DANGER

Internal components can be damaged or destroyed due to electrostatic discharge (ESD) during the handling of the device.

Take suitable precautions before handling the device to prevent electrostatic discharges through the sensor electronics. Such measures might include, for example, wearing an ESD bracelet. Transport and storage of electronic components may only be made in ESD-safe packaging.

Handle the device with particular care during dry meteorological conditions with relative humidity below 30% as electrostatic discharges can appear more frequently.

3 Application and design

3.1 Application

The electro-dynamic transducers PR 9268/01x-x00, PR 9268/20x-x00, PR 9268/30x-x00, PR 9268/60x-000, and PR 9268/70x-000 serve the measurement of absolute vibrations. They operate on the seismic measurement principle. A measuring coil, suspended on membrane springs, is the seismic mass of the transducer. By operating the transducer above the resonance frequency, the seismic mass will remain at rest. The relative motion between the transducer housing (moving with the measuring object) and the resting coil generates a voltage signal proportional to the vibration velocity.

3.2 Design

PR 9268/01x-x00

A robust construction and a splash-proof housing made of stainless steel permit the use of the transducer in hostile environments with temperatures up to 100°C. The transducer PR 9268/01x-x00 is available with different options. See [Table 3-1](#). [Figure 3-1](#) shows two transducer types, one with C-5015 Plug and one with non-armored cable.

Table 3-1: Order matrix

		PR 9268/	X	X	X	-	X	0	0
Measurement	Omni directional ≤100°C	0	1						
Cable	Armored 0 (3m), 1 (5m), 2 (8m), 3 (10)			X					
	Non-armored 4 (3m), 5 (5m), 6 (8m), 7 (10)								
	No cable (8)								
Cable End	HARTING						0	0	0
	OPEN CABLE END						1	0	0
	C-5015 Plug ¹						9	0	0

¹ Only available if "No cable (8)" is chosen.

Figure 3-1: PR 9268/01x-x00

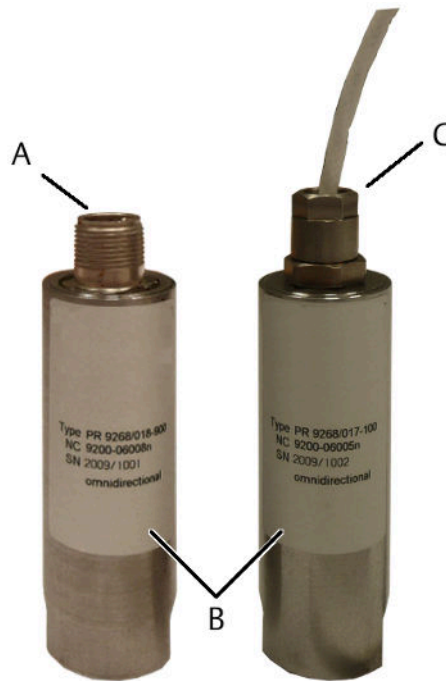

- A. Transducer PR 9268/018-900 without cable and C-5015 Plug
- B. Label
- C. Transducer with cable

PR 9268/20x-x00 and PR 9268/30x-x00

A robust construction and a splash-proof housing permit the use of the transducer in hostile environments with temperatures up to 100°C. The transducers PR 9268/20x-x00 and PR 9268/30x-x00 are available with different options. See [Table 3-2](#). [Figure 3-2](#) shows a transducer, Harting connector, and armored cable.

Both transducers are suitable for use in explosive hazardous areas (see [Hazardous location installation – PR 9268/20x-x00 and PR 9268/30x-x00](#)).

Table 3-2: Order matrix

		PR 9268/	X	X	X	-	X	0	0
Measurement	Vertical ≤100°C		2	0					
	Horizontal ≤100°C		3	0					
Cable	Armored 0 (3m), 1 (5m), 2 (8m), 3 (10)				X				
	Non-armored 4 (3m), 5 (5m), 6 (8m), 7 (10)								
Cable End	HARTING						0	0	0
	OPEN CABLE END						1	0	0

Figure 3-2: PR 9268/ 20x-x00 and PR 9268/30x-x00

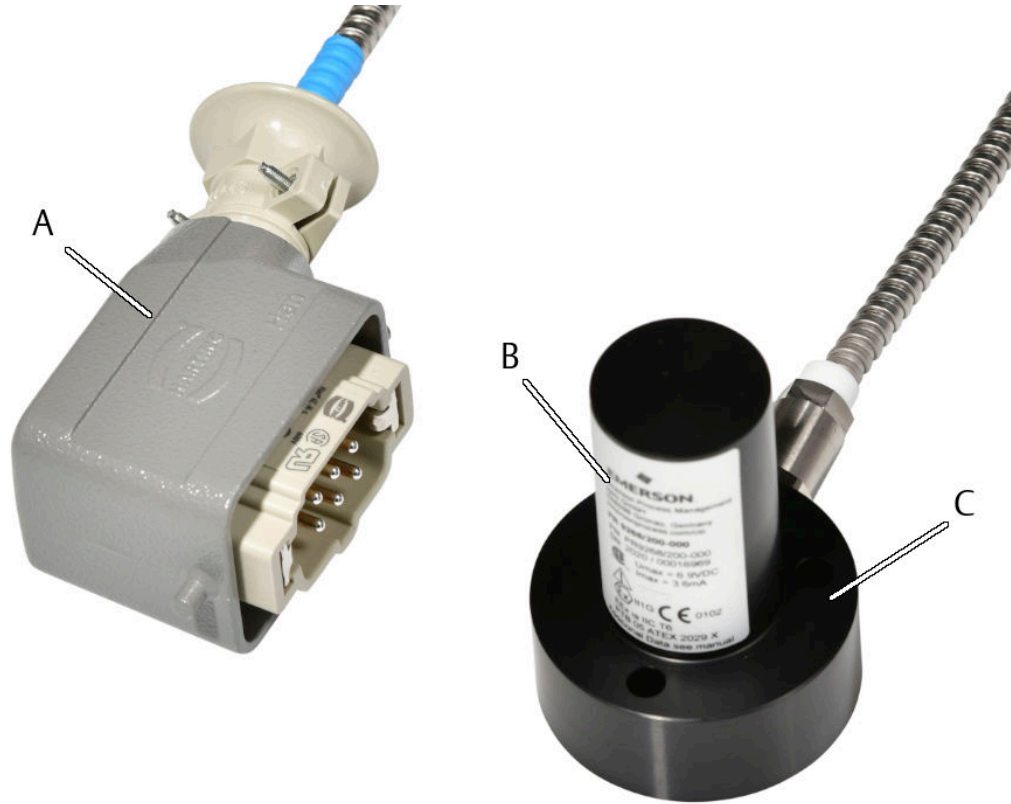

- A. Harting connector
- B. Label
- C. Transducer

PR 9268/60x-000 and PR 9268/70x-000

A robust construction and a splash-proof housing of stainless steel permit the use of the transducer in hostile environments with temperatures up to 200°C. The transducers PR 9268/60x-000 and PR 9268/70x-000 are available with different options. See [Table 3-3](#). [Figure 3-3](#) shows a transducer, Harting connector, and armored cable.

Because of an electric adaptation circuit in the Harting connector, the transducers have two sensitivities: 16.7 mV/(mm/s) and 22.0 mV/(mm/s) (standard). The selection of the sensitivity is made by using different connection points in the Harting connector.

Both transducers are suitable for use in explosive hazardous areas (see [Hazardous location installation – PR 9268/60x-000 and 9268/70x-000](#)).

Table 3-3: Order matrix

		PR 9268/	X	X	X	-	0	0	0
Measure ment	Vertical (up to 200°C)	6	0						
	Horizontal (up to 200°C)	7	0						

Table 3-3: Order matrix (continued)

		PR 9268/	X	X	X	-	0	0	0
Cable	Armored 0 (3m), 1 (5m), 2 (8m), 3 (10)			X					
	Non-armored 4 (3m), 5 (5m), 6 (8m), 7 (10)								
Cable End	HARTING						0	0	0

Figure 3-3: PR 9268/60x-000 and PR 9268/70x-000

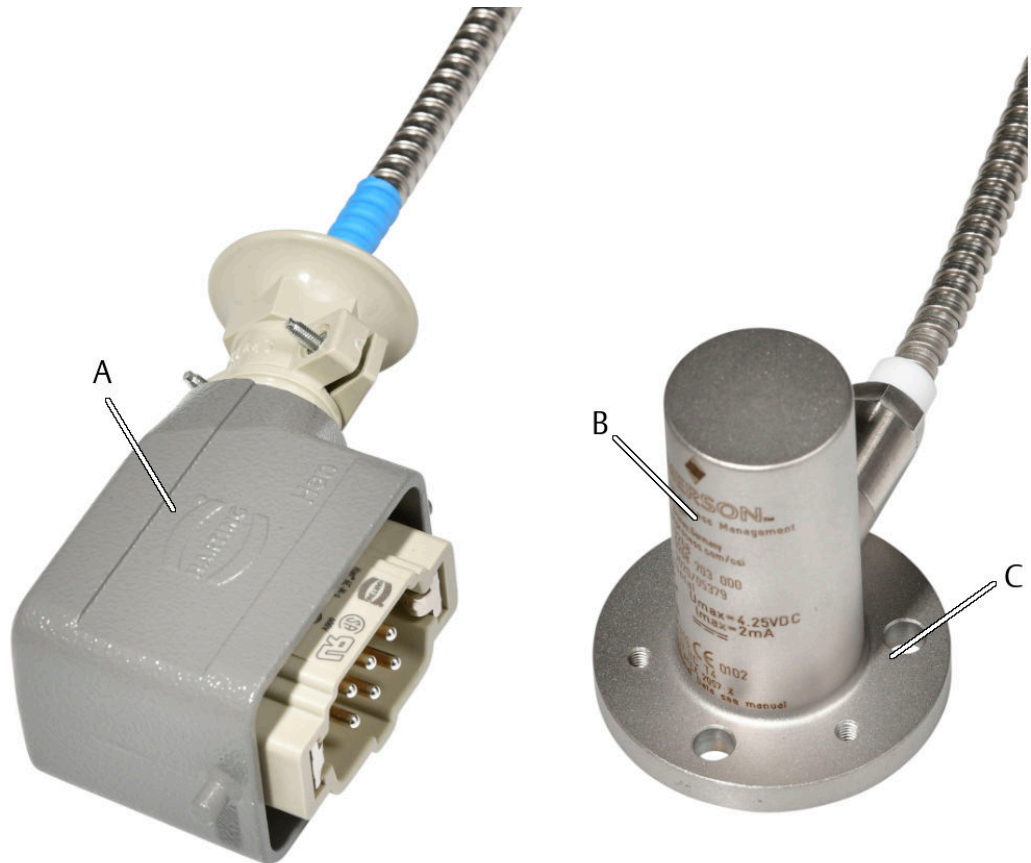

- A. Harting connector
- B. Label
- C. Transducer

4 Installation and commissioning

4.1 Hints for installation and connection

⚠ DANGER

Do not expose the transducer to hard shocks and do not drop it. This could lead to internal damages and thus to impairment or loss of sensitivity.

Mount the transducer on a flat and clean surface. Firmly tighten the mounting screws to ensure correct measurement.

PR 9268/01x-x00

Mount the transducer by using the included M10x1 to M6 bolt. A drill-hole with a corresponding depth and a M6 thread is required (see [Figure 6-5](#)).

1. Place an open-end wrench (WS 27) at the lower spanner flat (see [Figure 4-1](#) for position)

Note

Do not use the upper spanner flat to tighten the transducer.

2. Tighten the transducer with a torque of 3.8 Nm to 4.4 Nm.

Figure 4-1: Spanner flat position

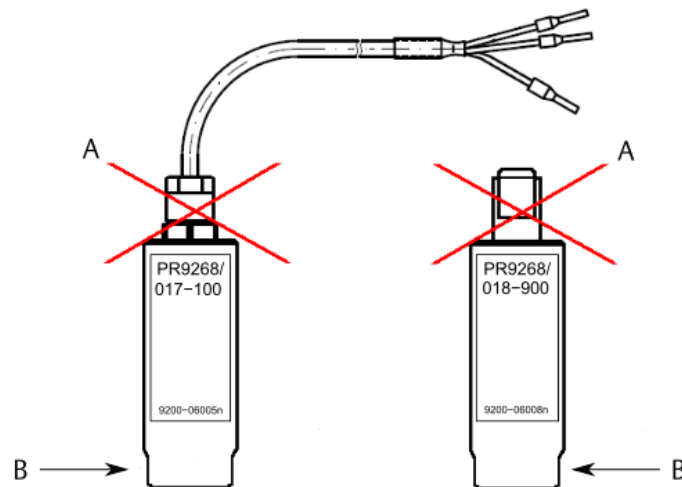

- A. Upper spanner flat – do not use
- B. Lower spanner flat (WS 27)

Install the cable without torsion and elongation and protect it against damage. If you install a transducer with a metal protection hose, use a clamp to fix the metal protection hose as closely as possible to the transducer.

See [Figure 4-2](#) and [Table 4-1](#) for wire colors of PR 9268/01x-x00 transducers with open cable end. The cable shield is not connected to the transducer housing.

Figure 4-2: Wire colors – PR 9268/01x-x00

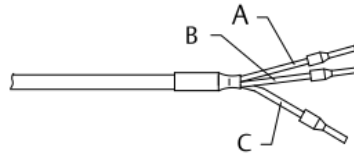
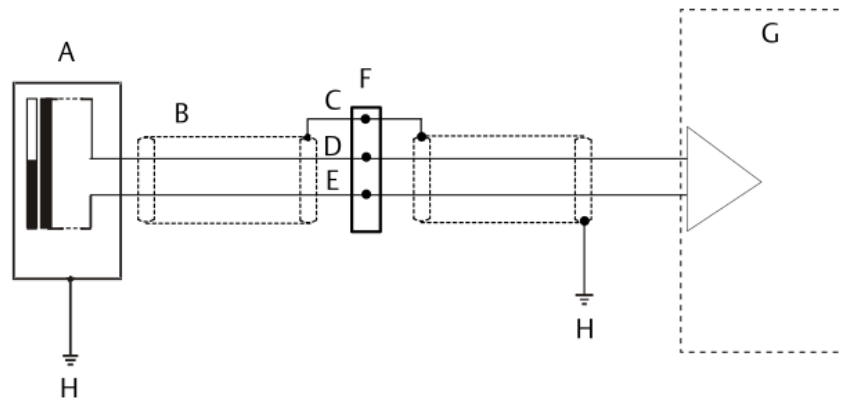

Table 4-1: Wire colors – PR 9268/01x-x00

Letter	Wire color	Meaning
A	Green	Signal high
B	Blue	Signal low
C	Black	Cable shield

See [Figure 4-3](#) for circuit and connection diagram.

Figure 4-3: Connection – open cable end



- A. Transducer
- B. Sensor cable
- C. Black wire, cable shield
- D. Blue wire, signal low
- E. Green wire, signal high
- F. Junction box
- G. Protection card
- H. Ground

[Figure 4-4](#) shows the C-5015 plug of the PR 9268/018-900 transducer. Connect the sensor corresponding to [Figure 4-3](#).

Figure 4-4: PR 9268/018-900 – C-5015 plug

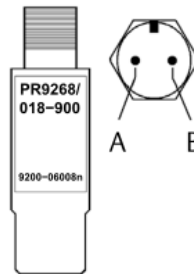

- A. 1: Signal A (high)
- B. 2: Signal B (low)

Pin assignment Harting plug

The pin assignment of the Harting plug of PR 9268/01x-000 transducers is as follows.

Table 4-2: Pin assignment of Harting plug – PR 9268/01x-000

Pin number Harting plug	Assignment
1	Not used
2	Signal low
3	Signal high
4	Not used
5	Not used
6	Cable shield

Note

The metal protection hose of the transducers with an armored cable is insulated from cable shield and transducer housing.

PR 9268/20x-x00 and PR 9268/30x-x00

Mount the transducers either with three M6 screws by using the through bores or with three M4 screws by using the blind hole threads (thread depth maximum 10 mm). See [Figure 4-5](#) for the position of the required mounting threads.

Figure 4-5: Position of mounting threads

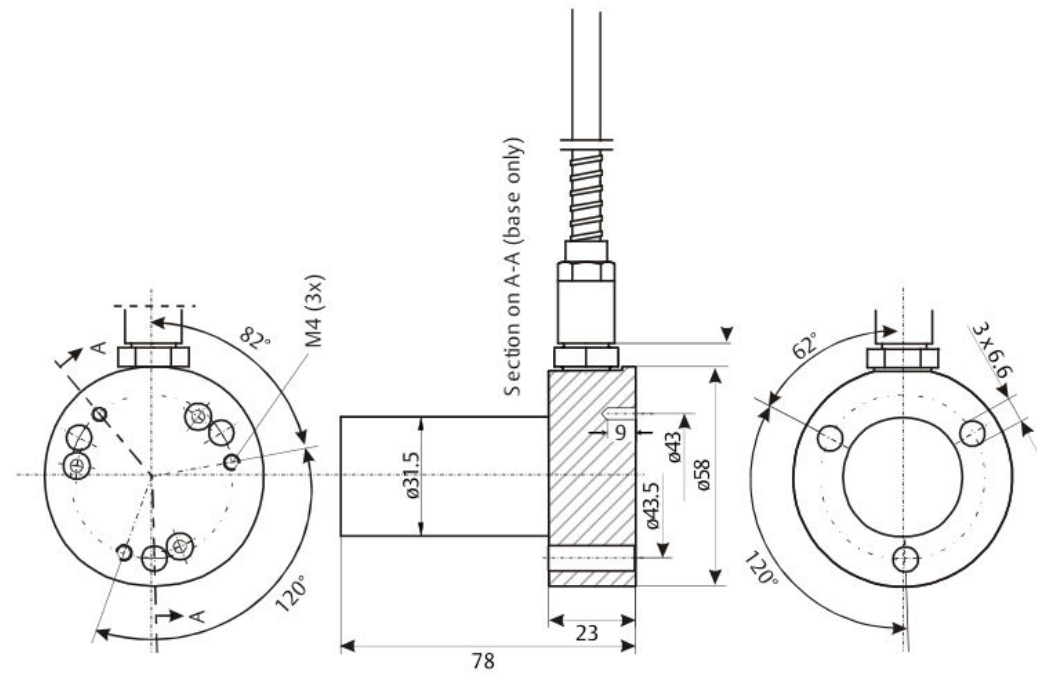

All dimensions in mm.

Install the cable without torsion and elongation and protect it against damage. If you install a transducer with a metal protection hose, use a clamp to fix the metal protection hose as closely as possible to the transducer.

See [Figure 4-6](#) and [Table 4-3](#) for wire colors of PR 9268/20x-x00 and PR 9268/30x-x00 transducers with open cable end. The cable shield is not connected to the transducer housing.

Figure 4-6: Wire colors – PR 9268/20x-x00 and PR 9268/30x-x00

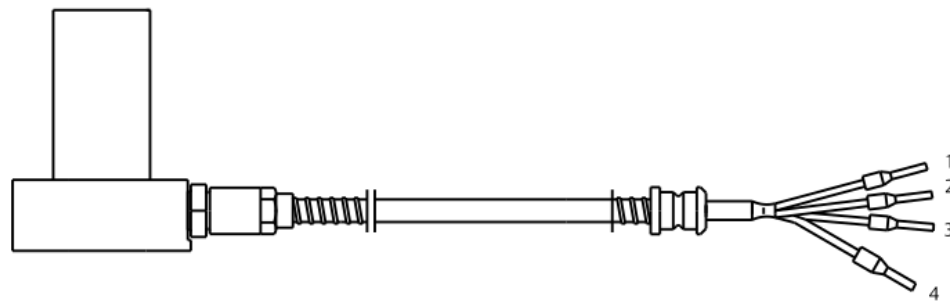

Table 4-3: Wire colors – PR 9268/20x-x00 and PR 9268/30x-x00

Number	Color	Meaning
1	Green	Signal high
2	Blue	Signal low

Table 4-3: Wire colors – PR 9268/20x-x00 and PR 9268/30x-x00 (continued)

Number	Color	Meaning
3	Red	Transducer housing
4	---	Cable shield

See [Figure 4-7](#) for circuit and connection diagram. Connect pin 5 of the Harting plug or the red wire to protective machine earth only if the transducer housing is mounted without earth-connection or due to national standards, with respect to Ex-i regulations or customer's demands.

Figure 4-7: Connection diagram

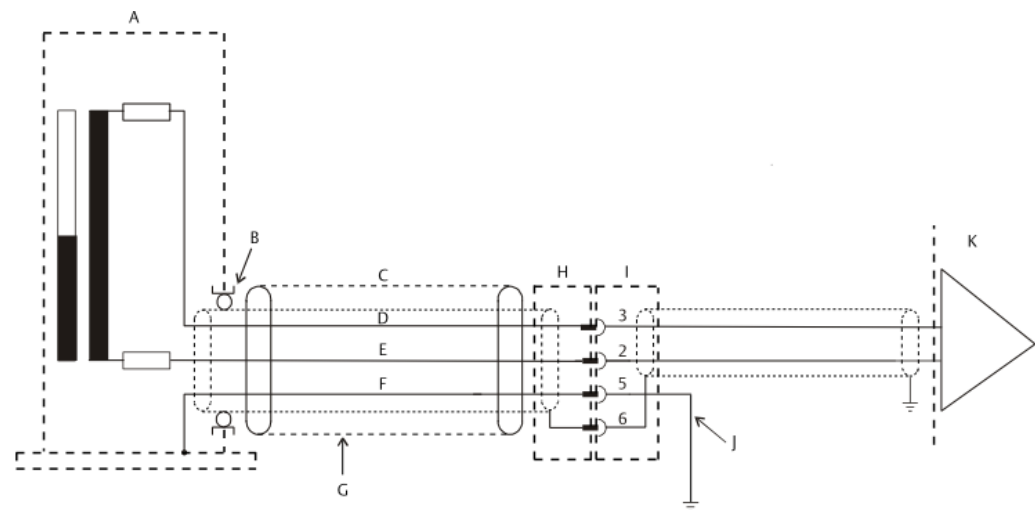

- A. Transducer PR 9268/20x-x00, PR 9268/30x-x00
- B. Insulated
- C. 3 m cable (standard)
- D. Green wire
- E. Blue wire
- F. Red wire
- G. Metal tube, connect to protective earth by metal clamps.
- H. Harting plug
- I. Harting socket
- J. Ground, only if transducer is mounted isolated.
- K. Protection card

Note

The metal protection hose of the transducers with an armored cable is insulated from cable shield and transducer housing.

PR 9268/60x-000 and PR 9268/70x-000

The Harting connectors of the PR 9268/60x-000 and PR 9268/70x-000 transducers contain a resistor network. Install the Harting connector only in environments with temperatures not higher than 100°C. Do not open the connector.

Emerson recommends to use the enclosed screws M6x20, washers, and spring washers to mount the transducers. The transducers have three through bores with a diameter of 6.6 mm and three M4 threaded holes for an alternative mounting option. See [Figure 4-8](#) for the position of the mounting holes.

Figure 4-8: Position of mounting holes

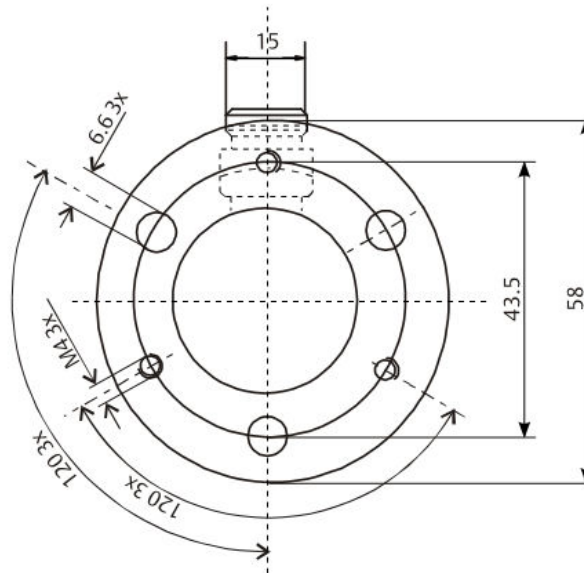

All dimensions in mm.

Install the cable without torsion and elongation and protect it against damage. If you install a transducer with a metal protection hose, use a clamp to fix the metal protection hose as closely as possible to the transducer.

Connect pin 5 of the Harting plug to protective machine earth only if the transducer housing is mounted without earth-connection or due to national standards, with respect to Ex-i regulations or customer's demands. See [Figure 4-9](#) for circuit and connection diagram.

Figure 4-9: Connection diagram

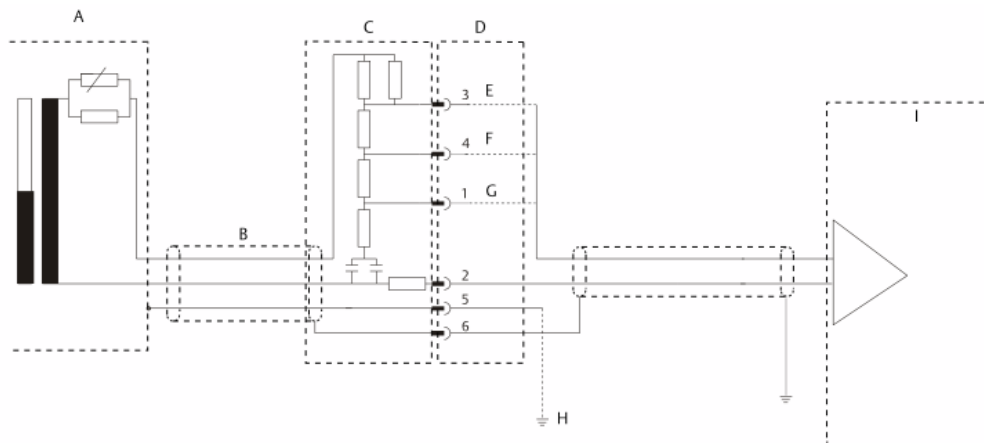

- A. Transducer PR 9268/60x-000, PR 9268/70x-000
- B. 3 m cable (standard)
- C. Harting plug
- D. Harting socket
- E. Sensitivity of 22.0 mV/(mm/s) for load 100 k Ω
- F. Sensitivity of 16.7 mV/(mm/s) for load 20 k Ω
- G. Sensitivity of 16.7 mV/(mm/s) for load 50 k Ω
- H. Ground, only if transducer is mounted isolated.
- I. Protection card

Note

The metal protection hose of the transducers with an armored cable is insulated from cable shield and transducer housing.

Connection PR 9268/20x-100-RAD, PR 9268/30x-100-RAD, PR 9268/60x-100-RAD, and PR 9268/70x-100-RAD

The transducers PR 9268/20x-100-RAD, PR 9268/30x-100-RAD, PR 9268/60x-100-RAD, and PR 9268/70x-100-RAD are designed for use in radioactive environments (radiation resistance: 8×10^5 Gy). The wire colors of these transducers differ from the wire colors of the standard types. See Figure 4-10, Figure 4-11, and Table 4-4.

Figure 4-10: Connection PR 9268/20x-100-RAD and PR 9268/30x-100-RAD

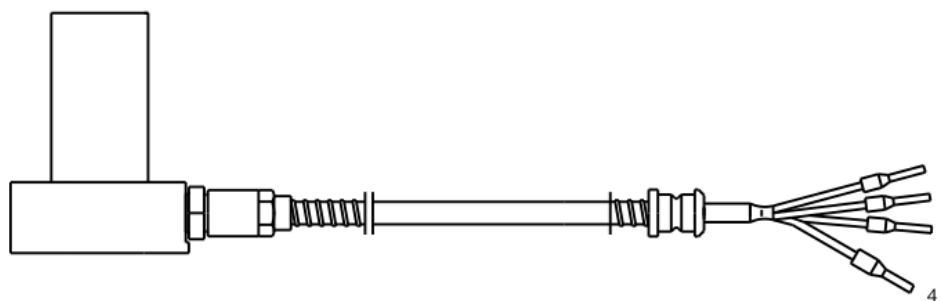

Figure 4-11: Connection PR 9268/60x-100-RAD and PR 9268/70x-100-RAD

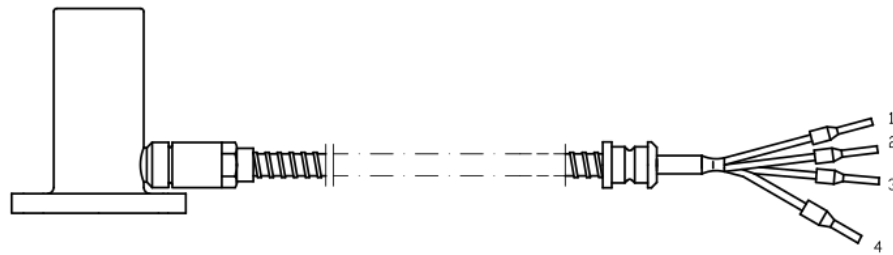

Table 4-4: Wire colors – all RAD types

Number	Wire color	Meaning
1	Black	Signal high
2	Brown	Signal low
3	Red	Transducer housing
4	White	Cable shield

4.2 CSA - Conditions of acceptability

PR 9268/01x-x00

⚠ CAUTION

The transducer PR 9268/01x-x00 may only be operated with devices that are supplied with safety low voltage (24 V). For this reason a power supply unit is required that meets the specifications of LPS (Low Power Source) according the EN/IEC 60950-1 or LV/LC (Low Voltage/Low Current) according the EN/IEC 61010-1. In addition, care should be exercised in the physical installation of the sensor. Wrong polarity and/or improper installation can result in false signals, which do not represent actual measured quantities.

PR 9268/20x-x00 and PR 9268/30x-x00

⚠ CAUTION

The transducers PR 9268/20x-x00 and PR 9268/30x-x00 may only be operated with devices that are supplied with safety low voltage (24 V). For this reason, a power supply unit is required that meets the specifications of LPS (Low Power Source) according the EN/IEC 60950-1 or LV/LC (Low Voltage/Low Current) according the EN/IEC 61010-1. In addition, care should be exercised in the physical installation of the sensor. Wrong polarity and/or improper installation can result in false signals, which do not represent actual measured quantities.

PR 9268/60x-000 and PR 9268/70x-000

⚠ CAUTION

The transducers PR 9268/60x-000 and PR 9268/70x-000 may only be operated with devices that are supplied with safety low voltage (24 V). For this reason, a power supply unit is required that meets the specifications of LPS (Low Power Source) according to the EN/IEC 60950-1 or LV/LC (Low Voltage/Low Current) according to EN/IEC 61010-1. In addition, care should be exercised in the physical installation of the sensor. Wrong polarity and/or improper installation can result in false signals, which do not represent actual measured quantities.

4.3 Installation requirements depending on mounting angle

The transducers PR 9268/20x-x00 and PR 9268/60x-000 are specified for vertical measurement ($\pm 60^\circ$). The transducers PR 9268/30x-x00 and PR 9268/70x-000 are specified for horizontal measurement ($\pm 30^\circ$). If the transducer is to be mounted in a direction different to the nominal measuring direction, Emerson recommends using a lifting or sinking current according to the angle deviation. The supplied current raises or drops the seismic mass of the sensor to keep it in the center of the movement range. Otherwise the possible measuring range will be reduced. See [Table 4-5](#) if a lifting or sinking current is required.

Note

The omni directional transducers PR 9268/01x-x00 can be mounted in every measuring direction without supplying any lifting or sinking currents.

Table 4-5: Lifting or sinking current

Transducer	Mounting angle range	Figure	Lifting current	Sinking current
PR 9268/20x-x00	-30° to +30°	Figure 4-12	no	no
PR 9268/60x-000	-30° to -60°	Figure 4-13	no	yes
	+30° to +60°		no	yes
PR 9268/30x-x00	-80° to -100°	Figure 4-14	no	no
	+80° to +100°		no	no
PR 9268/70x-000	-60° to -90°	Figure 4-15	yes	no
	+60° to +90°		yes	no
PR 9268/70x-000	-90° to -120°	Figure 4-16	no	yes
	+90° to +120°		no	yes

Note

Use the lifting current also as a sinking current. Activate the lifting current in the configuration software and reverse the polarity of the lifting current output at the Harting

connector. For further information see sensor connection chapters in the manuals of the respective protection cards (for example, A6120 or A6500-SR).

⚠ CAUTION

To ensure proper measuring function, install the transducer only within the described mounting angle ranges.

4.3.1 PR 9268/20x-x00 and PR 9268/60x-000 – without sinking current

The vibration transducers PR 9268/20x-x00 and PR 9268/60x-000 are designed for the vertical measurement direction (0° position). Without a sinking current, the maximum admissible deviation from the nominal position is $\pm 30^\circ$ in positive and negative direction. See [Figure 4-12](#).

Figure 4-12: Deviation of $\pm 30^\circ$ from the nominal direction

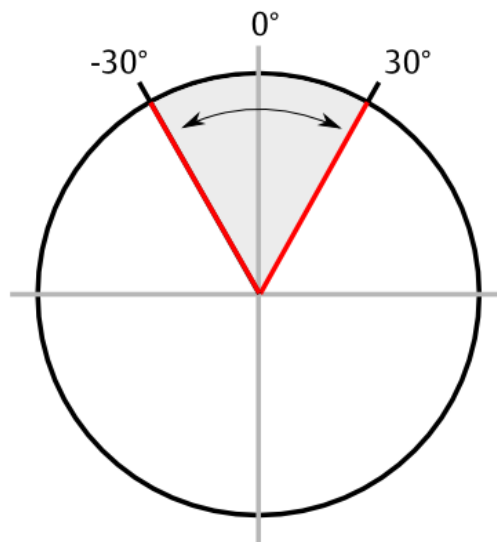

4.3.2 PR 9268/20x-x00 and PR 9268/60x-000 – with sinking current

The vibration transducers PR 9268/20x-x00 and PR 9268/60x-000 are designed for the vertical measurement direction (0° position). They can be used with a maximum deviation of $\pm 60^\circ$ in positive and in negative direction (related to the nominal direction 0°). See [Figure 4-13](#).

Figure 4-13: Deviation of $\pm 60^\circ$ from the nominal direction

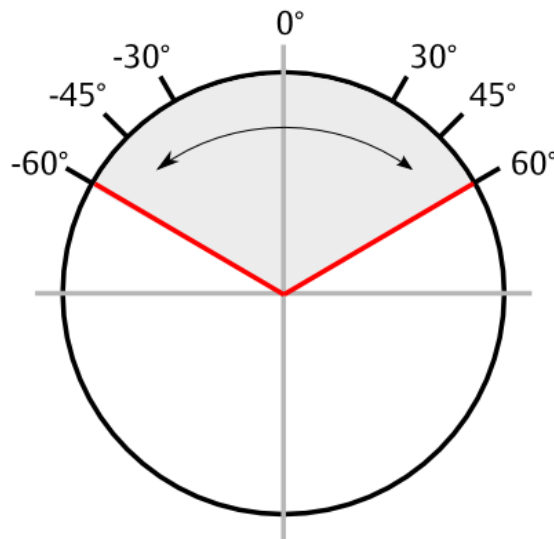

If the transducer is mounted in a position between -30° and -60° or $+30^\circ$ and $+60^\circ$, a sinking current is necessary to lower the seismic mass of the transducer to the middle of the working range. Define the required sinking current in the configuration of the used protection card (for example, A6120 or A6500-UM). The specified maximum sinking current for the PR 9268/20x-x00 is approximately 3.6 mA and for the PR 9268/60x-000 approximately 2.0 mA. These value are automatically used in the configuration when selecting the PR9268/20x-x00 or PR 9268/60x-000 from the sensor list of the configuration software. The configuration software calculates and sets the necessary lifting current in relation to measuring direction and mounting angle. See [Table 4-6](#) for some examples.

Table 4-6: Angle deviations and resulting sinking currents

Angle deviation	Sinking current	
	PR9268/20x-x00	PR 9268/60x-000
$\pm 30^\circ$	0.48 mA	0.27 mA
$\pm 45^\circ$	1.05 mA	0.59 mA
$\pm 60^\circ$	1.8 mA	1.0 mA

4.3.3 PR 9268/30x-x00 and PR 9268/70x-000 – without lifting/sinking current

The vibration transducers PR 9268/30x-x00 and PR 9268/70x-000 are designed for the horizontal measurement direction (90° position). Without a lifting/sinking current, the maximum admissible deviation from the nominal position is $\pm 10^\circ$ in positive and negative direction. See [Figure 4-14](#).

Figure 4-14: Deviation of $\pm 10^\circ$ from the nominal direction

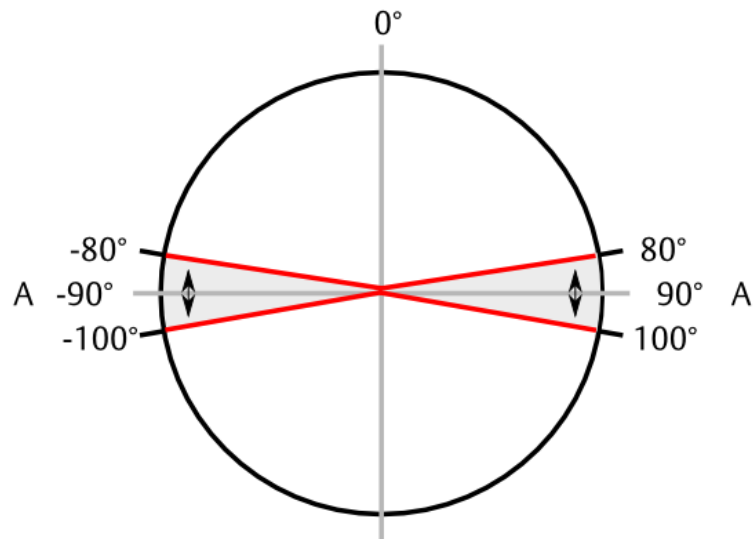

A. Nominal position

4.3.4

PR 9268/30x-x00 and PR 9268/70x-000 – with lifting current

The vibration transducers PR 9268/30x-x00 and PR 9268/70x-000 are designed for the horizontal measurement direction (90° position). They can be used with a maximum deviation of -30° (related to the nominal direction 90°). See [Figure 4-15](#).

Figure 4-15: Deviation of -30° from the nominal direction

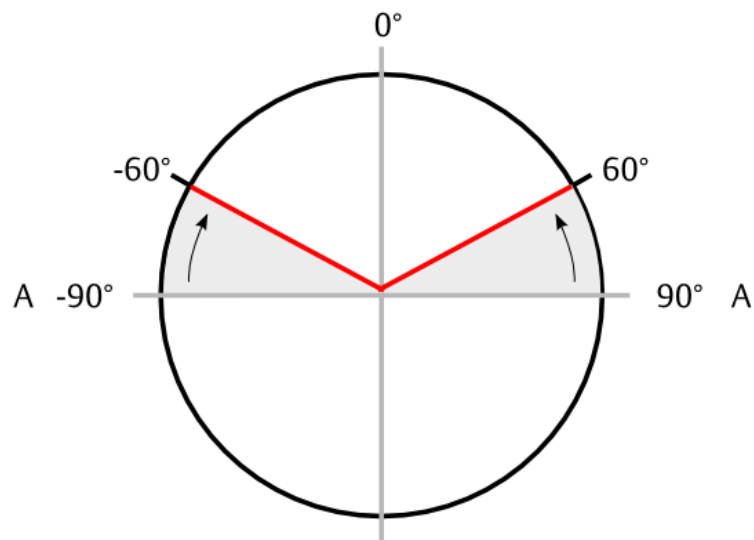

A. Nominal position

If the transducer is mounted in a position between -80° and -60° or 60° and 80° a lifting current is necessary to raise the seismic mass of the transducer to the middle of the working range. Define the required lifting current in the configuration of the used protection card (for example, A6120 or A6500-UM). The specified maximum lifting current for the PR 9268/30x-x00 is approximately 3.6 mA and for the PR 9268/70x-000 approximately 2.0 mA. These value are automatically used in the configuration when selecting the PR9268/30x-x00 or PR9268/70x-000 from the sensor list of the configuration software. The configuration software calculates and sets the necessary lifting current in relation to measuring direction and mounting angle. See [Table 4-7](#) for some examples.

Table 4-7: Angle deviations and resulting lifting currents

Angle deviation	lifting current	
	PR9268/30x-x00	PR 9268/70x-000
$\pm 80^\circ$	0.63 mA	0.35 mA
$\pm 70^\circ$	1.23	0.68 mA
$\pm 60^\circ$	1.8 mA	1.0 mA

4.3.5 PR 9268/30x-x00 and PR 9268/70x-000 – with sinking current

The vibration transducers PR 9268/30x-x00 and PR 9268/70x-000 are designed for the horizontal measurement direction (90° position). They can be used with a maximum deviation of $+30^\circ$ (related to the nominal direction 90°). See [Figure 4-16](#).

Figure 4-16: Deviation of $+30^\circ$ from the nominal direction

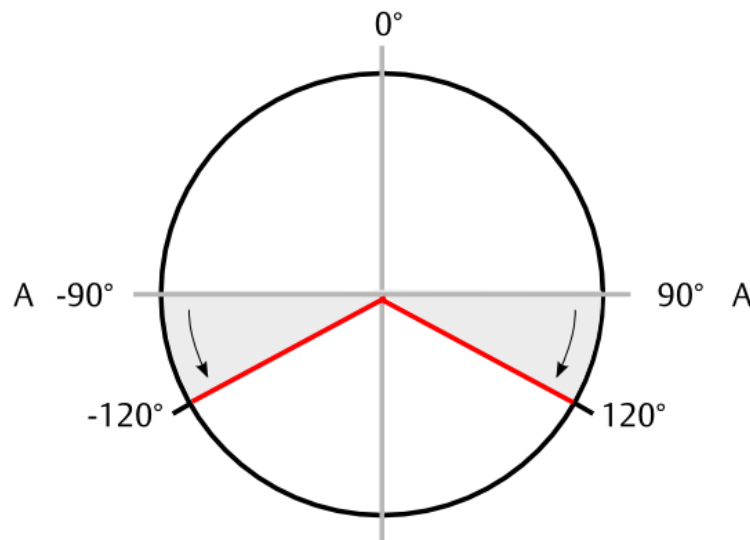

A. Nominal position

If the transducer is mounted in a position between -100° and -120° or 100° and 120° a sinking current is necessary to lower the seismic mass of the transducer to the middle of the working range. Define the required sinking current in the configuration of the used

protection card (for example, A6120 or A6500-UM). The specified maximum sinking current for the PR 9268/30x-x00 is approximately 3.6 mA and for the PR 9268/70x-000 approximately 2.0 mA . These values are automatically used in the configuration when selecting the PR9268/30x-x00 or PR 9268/70x-000 from the sensor list of the configuration software. The configuration software calculates and sets the necessary sinking current in relation to measuring direction and mounting angle. See [Table 4-8](#) for some examples.

Table 4-8: Angle deviations and resulting sinking currents

Angle deviation	Sinking current	
	PR9268/30x-x00	PR 9268/70x-000
±100°	0.63 mA	0.35 mA
±110°	1.23 mA	0.68 mA
±120°	1.8 mA	1.0 mA

5 Maintenance, fault finding, and repair

5.1 Maintenance

The transducer does not require any maintenance during operation.

5.2 Hints for fault finding

⚠ CAUTION

Any work on the system may impair machine protection.

If a problem occurs, perform the tests described in [Transducer resistance measurement](#), [Insulation resistance measurement](#), and [Signal generation check](#) for a first fault analysis.

5.2.1 Transducer resistance measurement

Procedure

1. Disconnect the transducer.
2. Use a resistance meter to measure the resistance between pin 2 and pin 3 of the Harting connector or between the blue wire and green wire if the transducer has an open cable end. [Table 5-1](#) displays resistance values and their meaning.

Table 5-1: Meaning of resistance values

Resistance values			Meaning / Error
PR 9268/01x-x00	PR 9268/20x-x00 and PR 9268/30x-x00	PR 9268/60x-000 and PR 9268/70x-000	
0 Ω	0 Ω	0 Ω	Short circuit
1723 Ω ±2 %	1875 Ω ±10 %	3270 Ω ±10 %	Transducer OK
∞ Ω	∞ Ω	∞ Ω	Cable break Connection to the transmitter has been interrupted

3. Reconnect the transducer or install a new one in case of a defect.

5.2.2 Insulation resistance measurement

Procedure

1. Disconnect the transducer.
2. Measure the insulation resistance.

Option	Description
PR 9268/20x-x00 PR 9268/30x-x00	Measure the insulation resistance between transducer coil connections (Harting connector: pin 2 and pin 3; open cable end: blue and green wire), cable shield, and transducer housing. Test voltage: maximal 100 V DC The insulation resistance must be higher than 1000 MΩ.
PR 9268/60x-000 PR 9268/70x-000	Measure the insulation resistance between transducer coil connections (Harting connector: pin 2 and pin 3), cable shield, and transducer housing. Test voltage: maximal 500 V DC The insulation voltage must be higher than 1 MΩ.

3. Reconnect the transducer or install a new one in case of a defect.

5.2.3 Signal generation check

Procedure

1. Disconnect the transducer.
2. Connect an AC millivolts meter to the coil connections (Harting connector: pin 2 and pin 3; open cable end: blue and green wire) and gently shake the transducer in measuring direction.

Option	Description
PR 9268/01x-x00	Depending on the movement, a voltage of approximately 300 mV can be generated.
PR 9268/20x-x00 PR 9268/30x-x00	Depending on the movement, a voltage of approximately 1 V to 2 V AC can be generated.
PR 9268/60x-000 PR 9268/70x-000	Depending on the movement, a voltage of approximately 1 V AC can be generated.

3. Reconnect the transducer or install a new one in case of a defect.

5.3 Repair

Repair or calibration is only possible at Emerson.

6 Technical data

Only specifications with indicated tolerances or limit values are required. Data without tolerances or without error limits are informative data and not guaranteed. Technology is under constant development, and specifications are subject to change without notice.

6.1 Measuring principle

Common

Low tuned measuring principle for absolute vibrations	
Mechanical / electrical conversion	Electro-dynamic

PR 9268/01x-x00

Measuring direction	Omni directional
---------------------	------------------

PR 9268/20x-x00 and PR 9268/30x-x00

Measuring direction	PR 9268/20x-x00: vertical	
	PR 9268/30x-x00: horizontal	
Maximum deviation from nominal measuring direction	PR 9268/20x-x00	± 30° without sinking current
		± 60° with sinking current ¹
	PR 9268/30x-x00	± 10° without lifting/sinking current
		± 30° with lifting/sinking current ¹

¹ Reduced accuracy without lifting/sinking current.

PR 9268/60x-000 and 9268/70x-000

Measuring direction	PR 9268/60x-000: vertical	
	PR 9268/70x-000: horizontal	
Maximum deviation from nominal measuring direction	PR 9268/60x-000	± 30° without sinking current
		± 60° with sinking current ¹
	PR 9268/70x-000	± 10° without lifting/sinking current
		± 30° with lifting/sinking current ¹

¹ Reduced accuracy without lifting/sinking current.

6.2 Operating ranges

Common

Vibration amplitude at nominal mounting position	±1500 μm
	500 μm peak-peak (PR 9268/01x-x00)
Limit stops	±2000 μm
Permissible acceleration in measuring direction	10 g continuous, 20 g short-time
Permissible acceleration in transverse direction	2 g
Linearity error of sensitivity	<2 %
Operation range at nominal mounting position	See nomogram (Figure 6-1 or Figure 6-2 for PR 9268/01x-x00) for interdependence between vibration amplitude, velocity, acceleration, and frequency .

Figure 6-1: Nomogram operating range

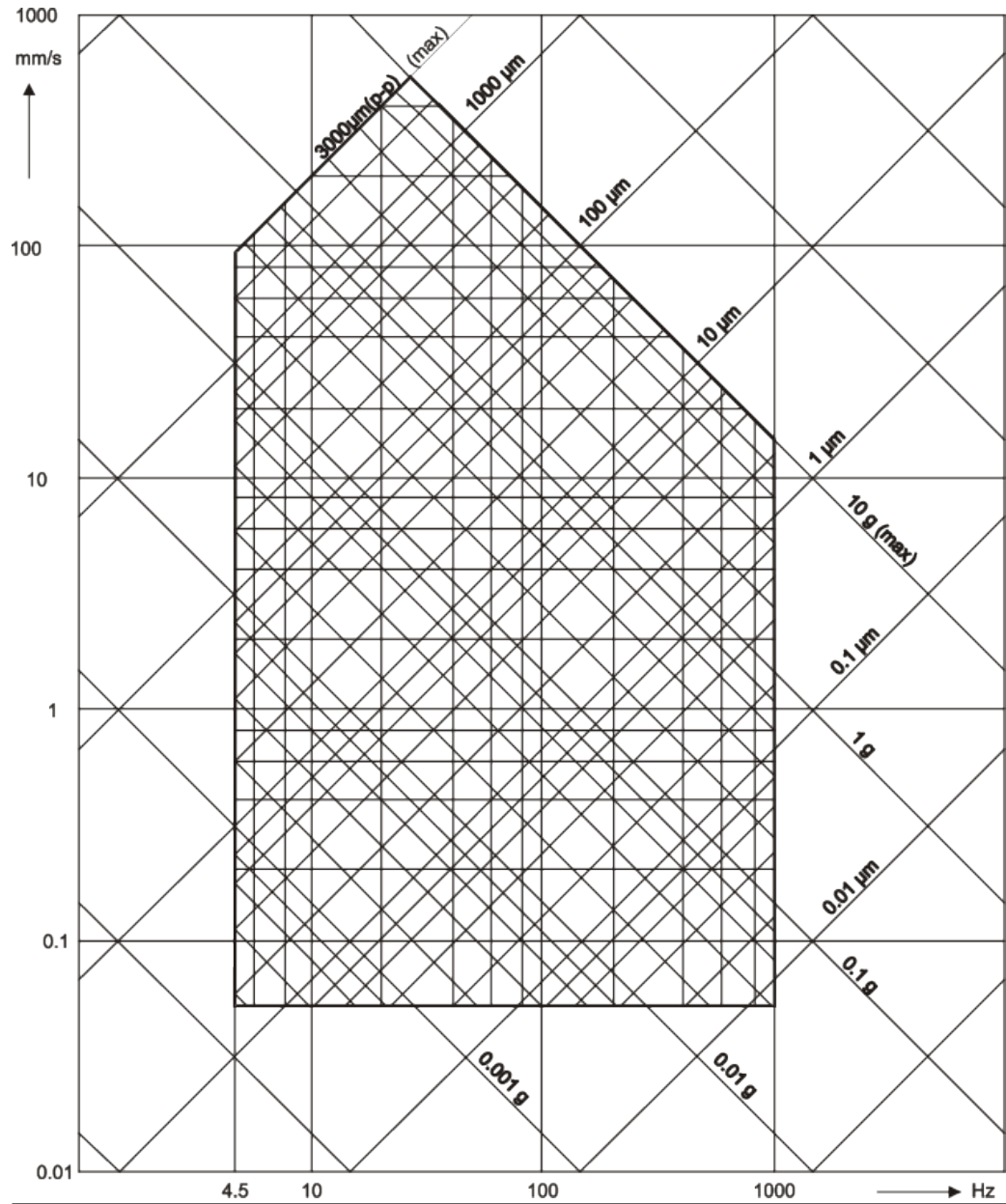
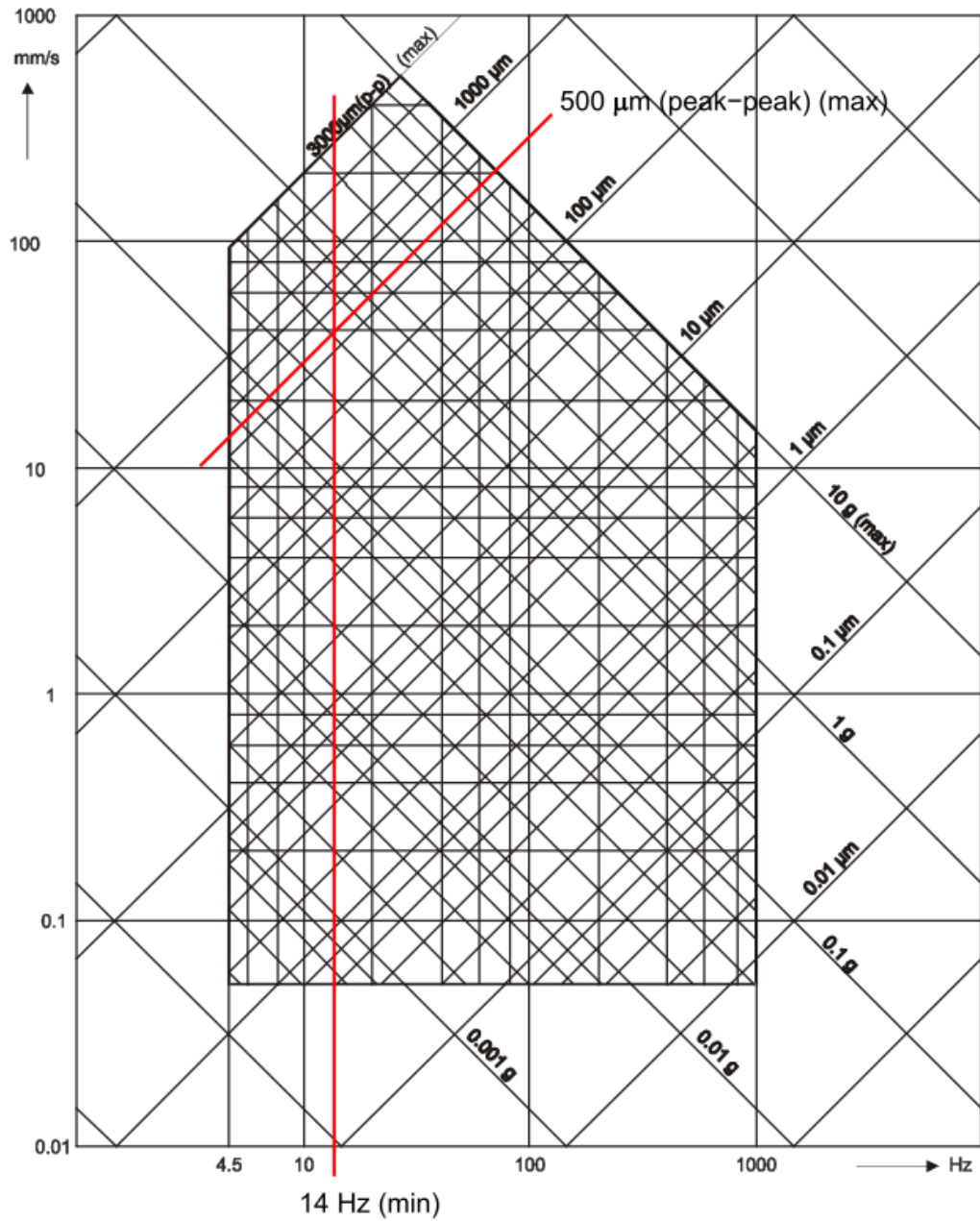

Figure 6-2: Nomogram operating range – PR 9268/01x-x00



Red lines: Limits of the PR 9268/01x-x00 transducer

PR 9268/01x-x00

Frequency range	14 Hz to 1000 Hz
Natural frequency	14 Hz
Transverse sensitivity	<0.1 g at 80 Hz

Sensitivity	17.5 mV/(mm/s) $\pm 8.5\%$ (nominal value at 20°C, 80 Hz, and 100 k Ω load)
Dumping factor	Approximately 0.6

PR 9268/20x-x00 and PR 9268/30x-x00

Frequency range	4 Hz to 1000 Hz
Natural frequency	4.5 Hz ± 0.75 Hz (at 20°C and 100 k Ω load)
Transverse sensitivity	0.13 at 110 Hz (PR 9268/20x-x00; vertical mounting)
	0.27 at 110 Hz (PR 9268/30x-x00; horizontal mounting)
Sensitivity	28.5 mV/(mm/s) $\pm 5\%$ (nominal value at 20°C, 80 Hz, and 100 k Ω load)
Dumping factor	0.56 (at 20°C and 100 k Ω load)
	0.42 (at 100°C and 100 k Ω load)

PR 9268/60x-000 and 9268/70x-000

Frequency range	10 Hz to 1000 Hz
Natural frequency	8.0 Hz ± 1.5 Hz (at 20°C and 100 k Ω load)
Transverse sensitivity	0.1 at 80Hz
Sensitivity	Nominal value at 20°C and 80 Hz
Pin 3, 100 k Ω electrical load	22.0 mV/(mm/s) $\pm 5\%$
Pin 1, 50 k Ω electrical load	16.7 mV/(mm/s) $\pm 5\%$
Pin 4, 20 k Ω electrical load	16.7 mV/(mm/s) $\pm 5\%$
Dumping factor	Approximately 0.7 (at 100 k Ω load)

6.3 Electrical data

PR 9268/01x-x00

Resistance measuring coil	1732 $\Omega \pm 2\%$
Inductance	<90 mH
Active capacity including cable	<1.2 nF

PR 9268/20x-x00 and PR 9268/30x-x00

Resistance measuring circuit	1875 $\Omega \pm 10\%$ (resistive load)
Resistance only measuring coil	375 $\Omega \pm 10\%$ (resistive load)
Active inductance	<90 mH
Active capacity including cable	<1.2 nF

Insulation resistance	>1000 MΩ (test voltage <100 V DC)
Recommended maximum lifting current for installation deviating from nominal measuring direction	1.8 mA (PR 9268/20 maximum: 60° and PR 9268/30 maximum 30°)

PR 9268/60x-000 and 9268/70x-000

Resistance measuring circuit	
Measuring circuit pin 3 (statical)	3270 Ω ±10 %
Measuring circuit pin 1 (statical)	3770 Ω ±10 %
Measuring circuit pin 4 (statical)	3690 Ω ±10 %
Active inductance	<160 mH
Active capacity including cable	Insignificant
Insulation resistance	>100 MΩ (test voltage <100 V DC)
Recommended maximum lifting current for installation deviating from nominal measuring direction	1.0 mA (PR 9268/60 maximum: 60° and PR 9268/70 maximum 30°)

6.4 Environmental conditions and dimensions

Common

Temperature range for storage and transport		-40 to +100°C without packing -40 to +70°C with packing
Relative humidity		0 to 100%, (non-condensing in housing and plug)
Connection cable	PR 9268/20x-x00, PR 9268/30x-x00, PR 9268/60x-000, and 9268/70x-000	3 x 0.5 mm ² , shielded, coating PTFE, length: see Table 3-2 or Table 3-3
	PR 9268/01x-x00	FEP (coating) / PTFE (Isolation), 3 wires; AWG 20
Metal protection hose		Stainless steel
Minimum bending radius for cable and protection hose		35 mm

PR 9268/01x-x00

Operating temperature range	Transducer without connector	-20 to +100°C Short time (<4 hours) up to 120°C
Protection class		IP 65
Housing	Dimensions	See Figure 6-3 , Figure 6-4 , and Figure 6-5
	Material	1.4104
Connector		6-pole Harting plug (only PR 9268/01x-000 types)

		2-pole C-5051 plug (only PR 9268/018-900)
Weight	Sensor without cable	approximately 280 g

Figure 6-3: Dimensions – PR 9268/01x-x00

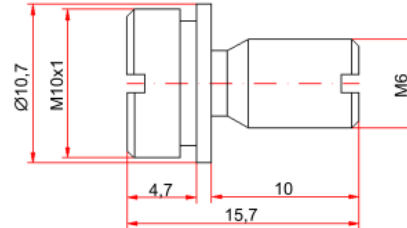

- A. Green: signal high
- B. Blue: signal low
- C. Black: cable shield

Figure 6-4: Dimensions – PE 9268/018-900

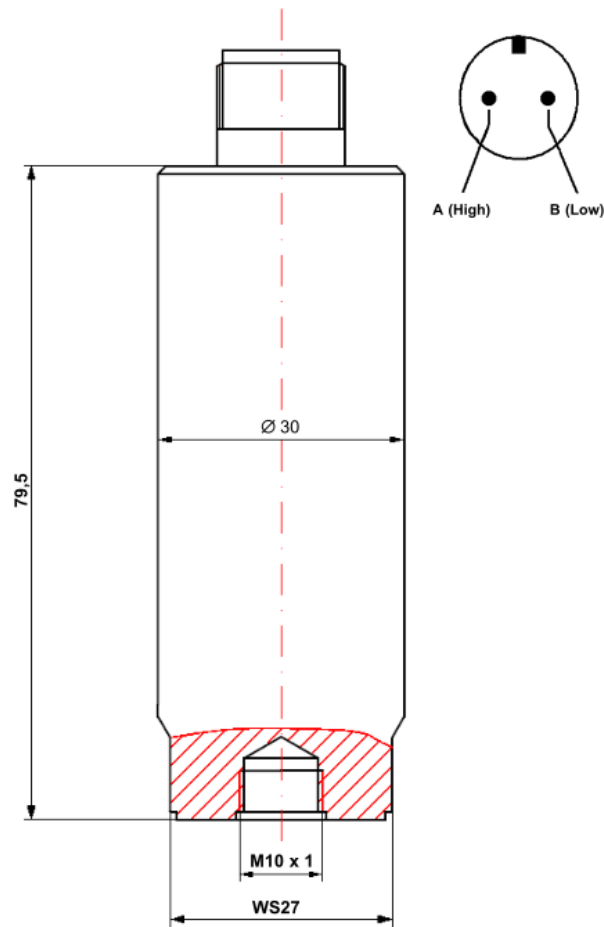
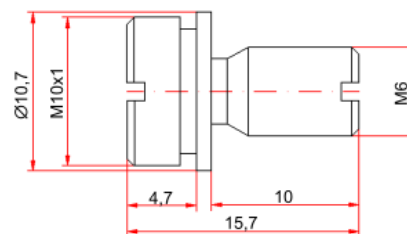

Figure 6-5: Dimensions – mounting bolt



PR 9268/20x-x00 and PR 9268/30x-x00

Operating temperature range	Transducer without connector	-20 to +100°C Short time (<4 hours) up to 120°C
	For connector	-40 to +125°C

Protection class		IP 55
Housing	Dimensions	See Figure 6-6
	Material	Al Mg Si Pb F28
Connector		6-pole Harting plug, 6-pole socket enclosed
Weight	Net weight, including cable, connector, and plug)	approximately 930 g
	Transducer only	approximately 260 g
	With packing	approximately 1200 g

Figure 6-6: Dimensions

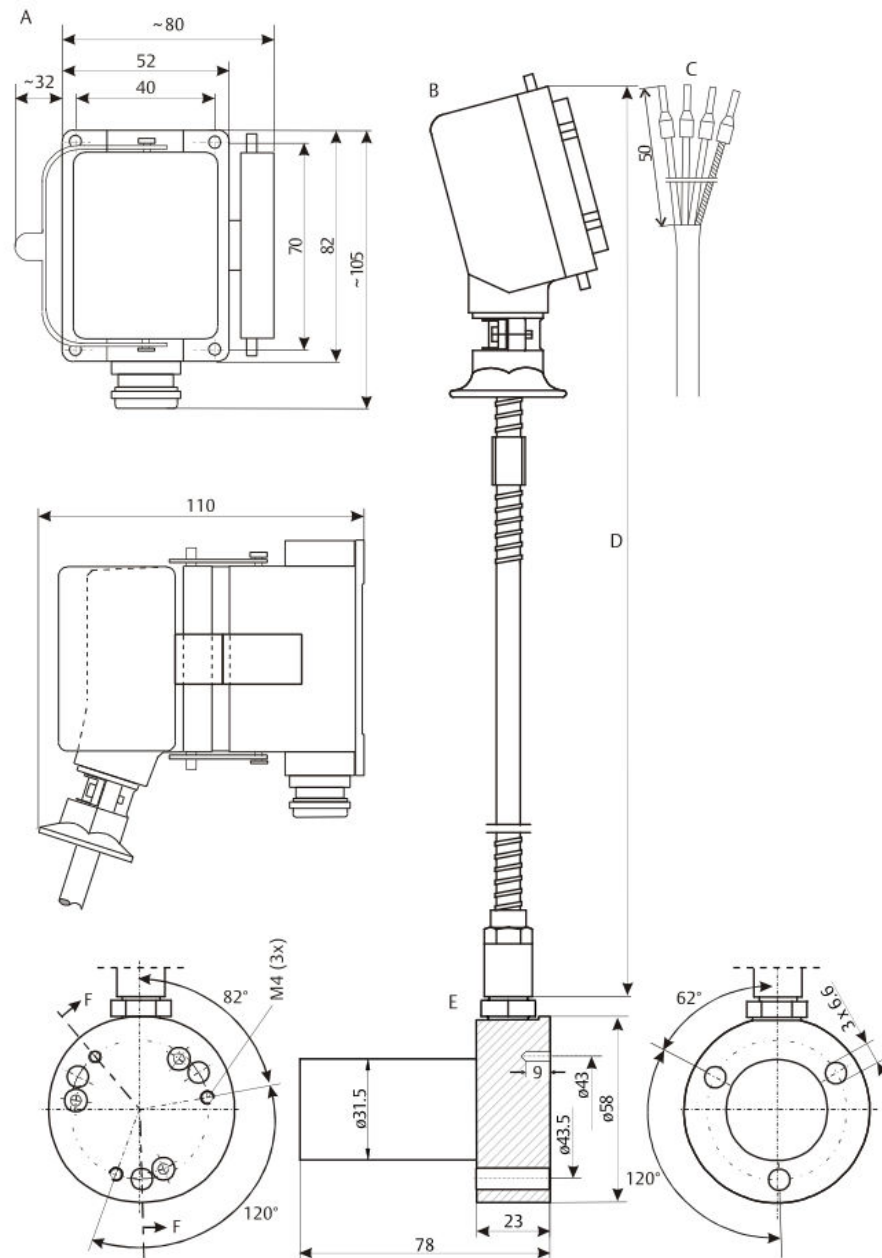

- A. Harting socket
- B. 6-pole Harting connector
- C. Open cable end
- D. Cable construction details (see [Table 3-2](#))
- E. Section on F-F (base only)

All dimensions in mm.

PR 9268/60x-000 and 9268/70x-000

Operating temperature range	Transducer without connector	-20 to +200°C
		Short time (<4 hours) up to 220°C
	For connector	-40 to +100°C
Protection class		IP 65
Housing	Dimensions	See Figure 6-7
	Material	Stainless steel
Connector		6-pole Harting plug with integrated resistor network, 6-pole socket enclosed
Weight	Net weight, including cable, connector, and plug)	approximately 1050 g
	Transducer only	<400 g (without cable und connector)
	With packing	approximately 1600 g

Figure 6-7: Dimensions

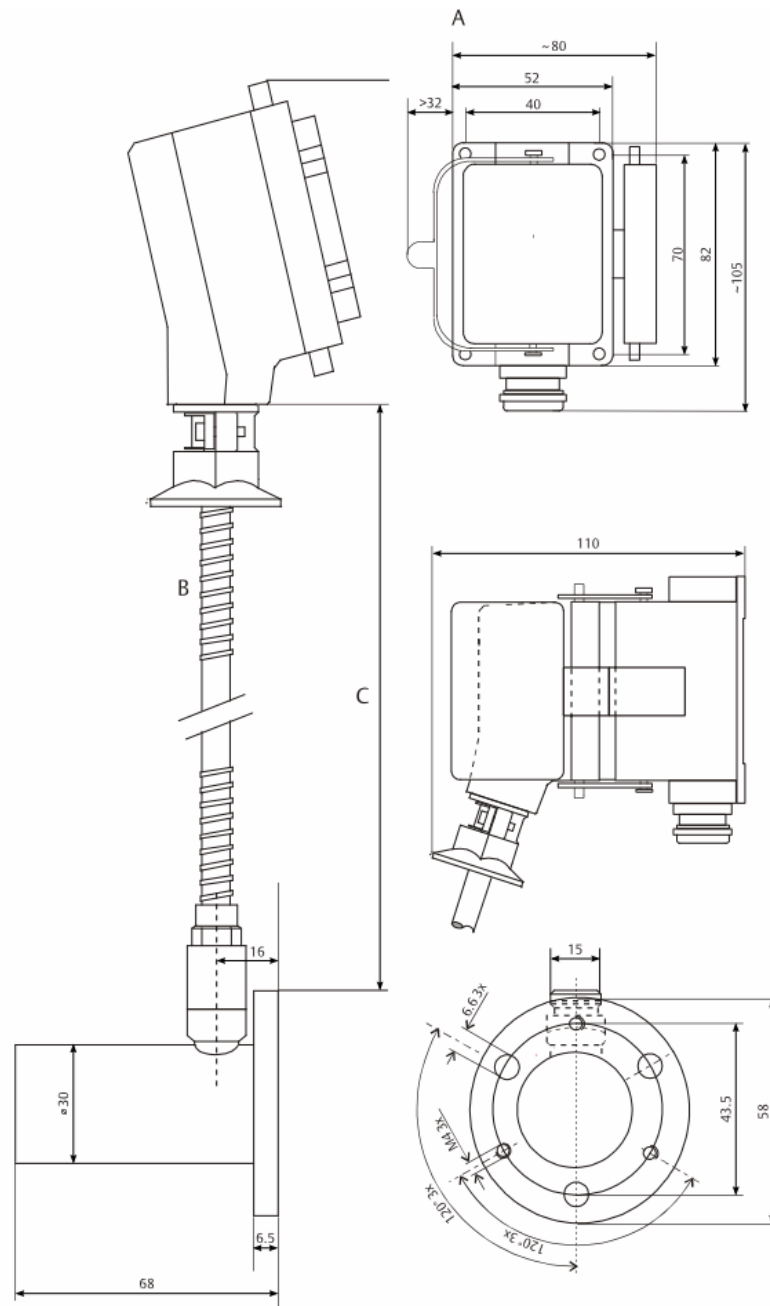

- A. Harting socket
- B. Minimum bending radius for cable and protection tube = 35 mm
- C. Cable construction details (see [Table 3-3](#))

All dimensions in mm.

7 Hazardous location installation

Version 1.2

7.1 Installation requirements

Absolute vibration transducers of type PR 9268/20x-x00, PR 9268/30x-x00, PR 9268/60(0-3)-000, and PR 9268/70(0-3)-000 may be installed, depending on the type (see [Table 7-1](#) and [Table 7-2](#)), in hazardous areas zone 0/1 to 2, protection class intrinsic safety, provided, the following conditions are met.

Note

The following points must be considered during installation of PR 9268/20x-x00, PR 9268/30x-x00, PR 9268/60(0-3)-000, and PR 9268/70(0-3)-000 sensors:

- The installation has to be made by using safety barriers, for example, of type Stahl, 9001/02-093-003-101, in accordance to:
 - [Figure 7-1](#) for PR 9268/20x-x00 and PR 9268/30x-x00
 - [Figure 7-3](#) for PR 9268/60x-000 and PR 9268/70x-000
 - [Figure 7-2](#) for an installation with two safety barriers (drawing is valid for PR 9268/20x-x00, PR 9268/30x-x00, PR 9268/60(0-3)-000, and PR 9268/70(0-3)-000))
- Field cabling is to be done according to EN IEC 60079-14.
- Both, sensor and Harting connector housings need to be connected to protective earth. This is possible via the fastening screws of the housings. EN / IEC 60079-14 is to be considered regarding the maximum permitted resistances.
- When using transducers with metal protection hose, this needs to be connected to earth with metal clamps.
- In Zone 0 the PR 9268/2xx-000 and PR 9268/3xx-000 housing and the Harting connector housing need to be protected by an additional protection device against the possibility of impact- or friction sparks.
- To observe the explosion protection, a mechanically reliable installation of the sensor at the measuring object must be ensured and a maximum acceleration of 10 g must not be exceeded.
- The national or local regulations have to be observed.

The following additionally points must be considered during installation of PR 9268/60x-000 and PR 9268/70x-000 sensors:

- The permission for the operating in explosive areas does only apply for the sensors with metal protection hose, these are the types PR9268/(60,70)(0-3)-000.
 - Sensors without metal protection hose, are not approved for the operating in explosive areas.
-

Table 7-1: PR 9268/20x-x00 and PR 9268/30x-x0 – permissible types

		PR 9268/	X	X	X	-	X	0	0
Measurement	Vertical	2	0						
	Horizontal	3	0						
Cable	Armored 0 (3m), 1 (5m), 2 (8m), 3 (10)			X					
	Non-armored 4 (3m), 5 (5m), 6 (8m), 7 (10)			X					
Cable End	HARTING						0	0	0
	OPEN CABLE END						1	0	0

Table 7-2: PR 9268/60x-000 and PR 9268/70x-000 – permissible types

		PR 9268/	X	X	X	-	0	0	0
Measurement	Vertical	6	0						
	Horizontal	7	0						
Cable	Armored 0 (3m), 1 (5m), 2 (8m), 3 (10)			X					
Cable End	HARTING						0	0	0

Connection cable

For explosion group IIC the total line capacity Cl (between the cable cores) of the connection cables and the barriers must not exceed the maximum permitted cable capacities and inductances.

Maximum permitted cable capacity PR 9268/2xx-000 and PR 9268/3xx-000: 275 nF

Maximum permitted cable capacity PR 9268/60x-000 and PR 9268/70x-000: 1125 nF

There is no additional limitation of the cable length in the hazardous area because of the cable capacity. The calculated maximum cable length based on the maximum permissible cable capacity exceeds the maximum technically permissible cable length of 1000 m.

7.2 Operation requirements

On operation in hazardous areas, the transducer must not be operated permanently outside its specification regarding vibration amplitude and acceleration.

7.3 Technical data, explosion protection

Specifications according to the EC-Type-Examination Certificate for PR 9268/20x, /30x, /60x, and /70x:

Table 7-3: ATEX/IECEX

PR 9268/20x-x00 and PR 9268/30x-x0	
Standards	EN IEC 60079-0:2018, Equipment - general requirements EN IEC 60079-11:2012, Intrinsically safe "i" EN IEC 60079-14:2014, Electrical installations design, selection and erection
Identification	1G Ex ia IIC T6 ... T4 Ga
	-20°C ≤ T _a ≤ +68°C for T6
	-20°C ≤ T _a ≤ +108°C for T4
PR 9268/60x-000 and PR 9268/70x-000	
Standards	EN IEC 60079-0:2018, Equipment - general requirements EN IEC 60079-11:2012, Intrinsically safe "i" EN IEC 60079-14:2014, Electrical installations design, selection and erection
Identification	2G Ex ib IIC T4 ... T3 Gb
	Sensor: -20°C ≤ T _a ≤ +125°C for T4 Connector: T _a ≤ 100°C for T4
	Sensor: -20°C ≤ T _a ≤ +190°C for T3 Connector: T _a ≤ 100°C for T3
General	
ATEX approval number	BVS 22 ATEX E 007 X
IECEX approval number	IECEX BVS 22.0009X

Table 7-4: General

Electrical data	
Safety barrier, example for II 1G and II 2G	Stahl 9001/02-093-003-101
PR 9268/20x-x00 and PR 9268/30x-x0	
Maximum values for the connection to an intrinsic safe electric circuit	U _i = 18.6 V I _i = 13 mA P _i = 18 mW L _i = 70 mH C _i = negligible
PR 9268/60x-000 and PR 9268/70x-000	
Maximum values for the connection to an intrinsic safe electric circuit	U _i = 18.6 V I _i = 6 mA P _i = 18 mW L _i = 148.6 mH C _i = 0.115 μF

7.4 Drawings

Figure 7-1: Connection example, intrinsically safe installation – PR 9268/20x-x00 and PR 9268/30x-x00

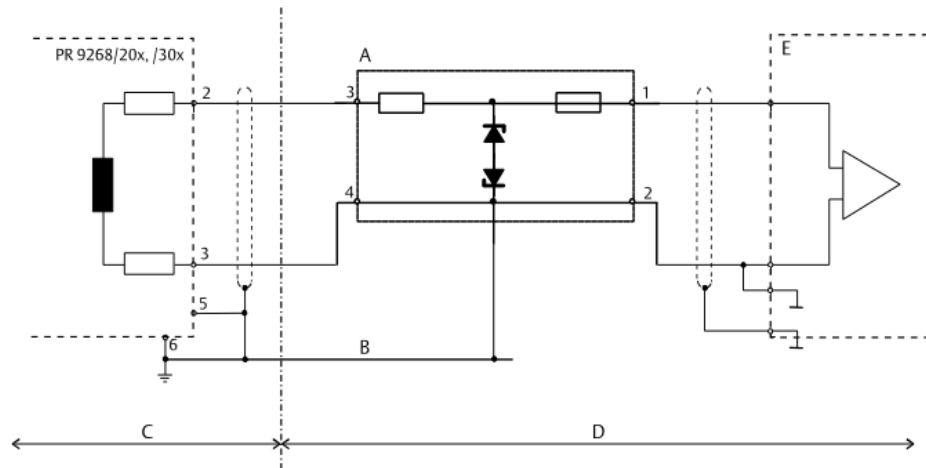

- A. Safety barrier 9001/02-093-003-101
- B. Potential equalizer
- C. Ex- hazardous area
- D. Non hazardous area
- E. Measurement amplifier

Figure 7-2: Connection example, potential free intrinsically safe installation with two safety barriers – PR 9268/20x-x00 and PR 9268/30x-x00

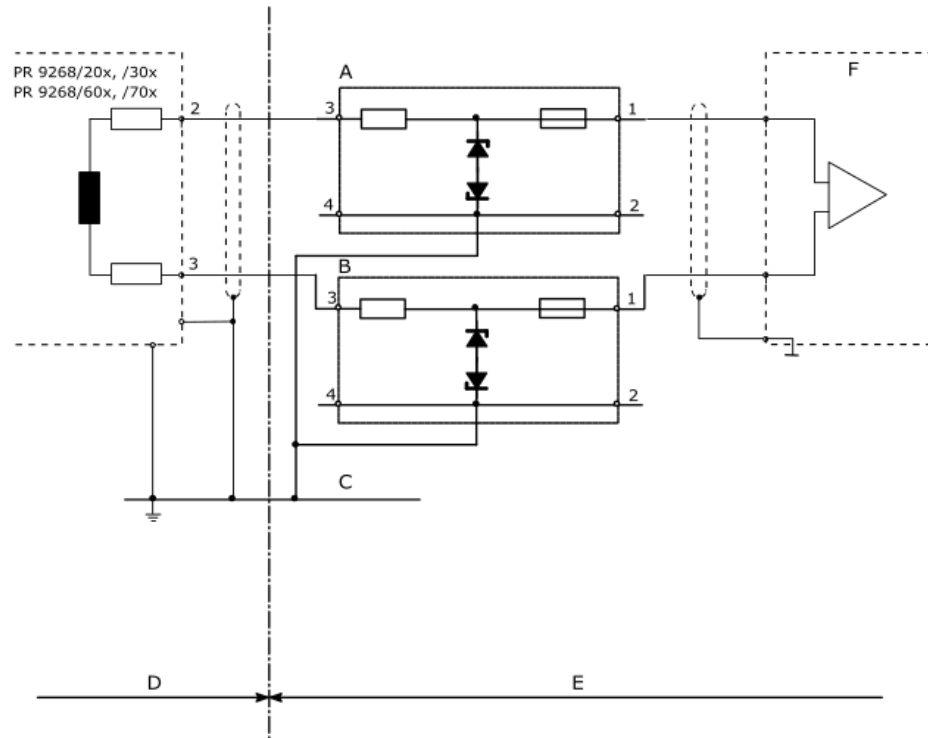

- A. Safety barrier 9001/02-093-003-101
- B. Safety barrier 9001/02-093-003-101
- C. Potential equalizer
- D. Ex- hazardous area
- E. Non hazardous area
- F. Measurement amplifier

Figure 7-3: Connection example, intrinsically safe installation – PR 9268/60x-000 and PR 9268/70x-000

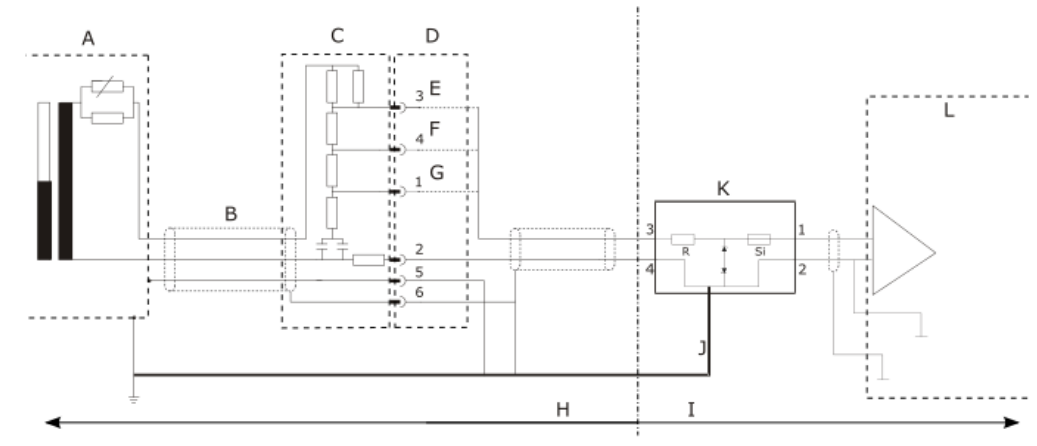

- A. Transmitter PR 9268/60x-000 or PR 9268/70x-000
- B. 3m cable (standard)
- C. Harting plug
- D. Harting socket
- E. Sensitivity of 22.0 mV/(mm/s) for load 100 k Ω
- F. Sensitivity of 16.7 mV/(mm/s) for load 20 k Ω
- G. Sensitivity of 16.7 mV/(mm/s) for load 50 k Ω
- H. Ex- hazardous area
- I. Non hazardous area
- J. Potential equalizer
- K. Safety barrier 9001/02-093-003-101
- L. Measurement amplifier

7.5 Revision history

Version	Date	Remarks / Changes
1.0	16. June 2016	Initial version
1.1	6. June 2018	Minor correction
1.2	17. March 2022	Recertification and restructuring

8 Certificates



EU-Declaration of Conformity (Translation)

We: epro GmbH, Jöbkesweg 3, 48599 Gronau
declare under our sole responsibility that following product(s) :

Product designation: PR 9268
Product description: Absolute Vibration Transducers, ATEX
Part numbers PR9268/20x-x00
PR9268/30x-x00
PR9268/60(0-3)-000
PR9268/70(0-3)-000

are in conformity with the terms of the directives mentioned below including any amendment valid at the date of declaration:

2014/30/EU Electromagnetic compatibility
2014/34/EU Equipment and protective system intended for use in potentially explosive atmospheres
2011/65/EU The restriction of the use of certain hazardous substances in electrical and electronic equipment

Following harmonized standards have been applied:

2014/30/EU EN 61326-1 Electrical equipment for measurement, control and laboratory use. EMC requirements.
Part 1. General requirements
2014/34/EU EN 60079-0 Explosive atmospheres -
Part 0: Equipment - General requirements
EN 60079-11 Explosive atmospheres -
Part 11: Equipment protection by intrinsic safety "i"
2011/65/EU EN 63000 Technical documentation for the assessment of electrical and electronic products with respect to the restriction of hazardous substances

For the type examination according to EN 60079-0 and EN 60079-11 the following notified body has been involved:

DEKRA Testing and Certification GmbH
Type examination certificate BVS 22 ATEX E 007 X

Authorized person for technical documentation:
Bruno Hecker, Jöbkesweg 3, 48599 Gronau

Gronau, 22 June 2022
Place, Date

Managing Director

Quality



EU-Declaration of Conformity (Translation)

We: epro GmbH, Jöbkesweg 3, 48599 Gronau
declare under our sole responsibility that following product(s):

Product designation: PR 9268
Product description: Absolute Vibration Transducers:
- with omni directional orientation or
- high temperature option without armed cables or
- customized versions

Part numbers PR9268/01x-x00 (omni directional orientation)
PR9268/60(4-7)-x00 (high temperature option without armed cables)
PR9268/70(4-7)-x00 (high temperature option without armed cables)
PR9268/xxx-xxx-yyy (yyy = customization)

are in conformity with the terms of the directives mentioned below including any amendment valid at the date of declaration:

2014/30/EU Electromagnetic compatibility
2011/65/EU The restriction of the use of certain hazardous substances in electrical and electronic equipment

Following harmonized standards have been applied:

2014/30/EU EN 61326-1 Electrical equipment for measurement, control and laboratory use. EMC requirements.
Part 1. General requirements
2011/65/EU EN 63000 Technical documentation for the assessment of electrical and electronic products with respect to the restriction of hazardous substances

Authorized person for technical documentation:

Bruno Hecker, Jöbkesweg 3, 48599 Gronau

Gronau, 22 June 2022
Place, Date

Managing Director

Quality



UKCA-Declaration of Conformity

We, the manufacturer: epro GmbH, Jöbkesweg 3, 48599 Gronau, Germany
declare under our sole responsibility that following product(s):

Product designation: PR 9268
Product description: Absolute Vibration Transducers, ATEX
Part numbers PR9268/20x-x00
PR9268/30x-x00
PR9268/60(0-3)-000
PR9268/70(0-3)-000

are in conformity with the terms of the directives mentioned below including any amendment valid at the date of declaration:

- S.I. 2016 No. 1091 Electromagnetic Compatibility Regulations 2016
- S.I. 2016 No. 1107 Equipment and Protective Systems Intended for use in Potentially Explosive Atmospheres Regulations 2016
- S.I. 2012 No. 3032 The restriction of the use of certain hazardous substances in electrical and electronic equipment

Following standards have been applied:

- S.I. 2016 No. 1091 EN 61326-1 Electrical equipment for measurement, control and laboratory use. EMC requirements. Part 1. General requirements
- S.I. 2016 No. 1107 EN 60079-0 Explosive atmospheres -Part 0: Equipment- General requirements
EN 60079-11 Explosive atmospheres- Part 11: Intrinsic Safety „I“
- S.I. 2012 No. 3032 EN IEC 63000 Technical documentation for the assessment of electrical and electronic products with respect to the restriction of hazardous substances

For the type examination according to EN 60079-0 and EN 60079-11 the following notified body has been involved:

DEKRA Testing and Certification GmbH
Type examination certificate BVS 22 ATEX E 007 X

Authorized person for technical documentation:

Bruno Hecker, Jöbkesweg 3, 48599 Gronau, Germany

Authorized Representative:

Emerson Process Management Limited,
company No 00671801
Meridian East,
Leicester
LE19 1UX, United Kingdom
Regulatory Compliance Department
email: ukproductcompliance@emerson.com
Phone: +44 11 6282 23 64

M. Fränzer
Managing Director

B. Hecker
Quality

Place, Date: Gronau, 13 September 2022



UKCA-Declaration of Conformity

We, the manufacturer: epro GmbH, Jöbkesweg 3, 48599 Gronau, Germany
declare under our sole responsibility that following product(s):

Product designation: PR 9268
Product description: Absolute Vibration Transducers:
- with omni directional orientation or
- high temperature option without armed cables or
- customized versions

Part numbers

PR9268/01x-x00	(omni directional orientation)
PR9268/60(4-7)-x00	(high temperature option without armed cables)
PR9268/70(4-7)-x00	(high temperature option without armed cables)
PR9268/xxx-xxx-yyy	(yyy = customization)

are in conformity with the terms of the directives mentioned below including any amendment valid at the date of declaration:

- S.I. 2016 No. 1091 Electromagnetic Compatibility Regulations 2016
S.I. 2012 No. 3032 The restriction of the use of certain hazardous substances in electrical and electronic equipment

Following standards have been applied:

- S.I. 2016 No. 1091 EN 61326-1 Electrical equipment for measurement, control and laboratory use. EMC requirements. Part 1. General requirements
S.I. 2012 No. 3032 EN IEC 63000 Technical documentation for the assessment of electrical and electronic products with respect to the restriction of hazardous substances

Authorized person for technical documentation:

Bruno Hecker, Jöbkesweg 3, 48599 Gronau, Germany

Authorized Representative:

Emerson Process Management Limited,
company No 00671801
Meridian East,
Leicester
LE19 1UX, United Kingdom
Regulatory Compliance Department
email: ukproductcompliance@emerson.com
Phone: +44 11 6282 23 64

M. Fränzer
Managing Director

B. Hecker
Quality

Place, Date: Gronau, 13 September 2022

Index

C

Connection 17
CSA 7, 24, 25
Current
 Lifting 25, 28
 Sinking 25, 26, 29

D

Disposal 9

E

ESD 12

F

Functional principle 13

M

Measuring direction
 horizontal 27–29
 vertical 26

N

Nomogram 34

R

RAD transducers 23
Radiation resistance 23

S

Seismic mass 13
Sensitivity 15, 23

T

Technical support 9

©2022, Emerson. All rights reserved.

The contents of this publication are presented for informational purposes only, and while diligent efforts were made to ensure their accuracy, they are not to be construed as warranties or guarantees, express or implied, regarding the products or services described herein or their use or applicability. All sales are governed by our terms and conditions, which are available on request. We reserve the right to modify or improve the designs or specifications of our products at any time without notice.

The Emerson logo is a trademark and service mark of Emerson Electric Co. The AMS logo is a mark of one of the Emerson family of companies. All other marks are the property of their respective owners.

